

# ROTARY MOWER

## TIGER 725



**PARTS**

**EN**

1<sup>th</sup> Edition 2026

 **GREENTEC**

*Cutting Edge Technology*



**IMPORTANT INFORMATION****GreenTec Tiger 725****PARTS****1<sup>th</sup>Edition – 2026**

**NOTICE:** Please ensure that this manual is handed to the operator before using the machine for the first time. If the machine is resold, the Parts list must be given to the new owner!

The information contained in this Parts list is correct at the time of publication. However, in the course of constant development, changes in specification are inevitable. Should you find the information given in this book different to the machine it relates to please contact the “After Sales Department” for advice.



Merkurvej 25  
DK 6000 Kolding  
Denmark  
Tel: +45 75553644  
Fax: +45 75554243  
Email: [info@greentec.eu](mailto:info@greentec.eu)  
web: [www.greentec.eu](http://www.greentec.eu)

## CONTENTS

<b>CONTENTS</b> .....	<b>4</b>
<b>INTRODUCTION</b> .....	<b>5</b>
<b>USEFUL INFORMATION</b> .....	<b>6</b>
<b>ORDERING PARTS</b> .....	<b>7</b>
<b>SPARE PARTS</b> .....	<b>8</b>
Tiger 725 cpl. ....	8
Joint for wing height (ADGT1567).....	10
Center body cpl. (ADGT1592).....	11
Splitter gearbox cpl.....	14
Outerwing gearbox cpl. ....	15
Innerwing gearbox cpl. ....	16
Center gearbox cpl.....	17
Cutting head Right/Left CW/CCW cpl. (ADGT1568/1569) .....	18
Wing Right/Left cpl. (ADGT1580R/1580L) .....	20
Outer wing rotor CW/CCW cpl. 6 blades (ADGT1578/1579).....	22
Outer wing rotor CW/CCW cpl. 3 blades (ADGT1582R/1582L) .....	23
Light cpl. Right/Left (ADGT1589R/1589L).....	24
Top link R/L cpl. (ADGT1571) .....	25
PTO inner wing cpl. (ADGT1590).....	26
PTO outer wing cpl. (ADGT1581) .....	28
PTO centre shaft cpl. (ADGT1591) .....	30
PTO Input shaft .....	32
Cylinder main lift ram.....	34
Cylinder for wing .....	35
Wing axle Right/Left cpl.....	35
Wheel axle .....	36
Tow link (ADGT1588).....	37
Linkage frame (ADGT1570) .....	37
Stickers .....	38

## INTRODUCTION

Dear customer!

Your new GreenTec machine is constructed with background in more than 20 years' experience with tractor-mounted machines to maintenance of green areas. This machine is produced by the latest technology and recognized safety regulations, standards and regulations.

We want to make a product available in such a way, that neither the use of the machine during transportation or maintenance of the machine causes any damage or misunderstandings.

This parts list contains information that are important and useful for maintaining your GreenTec machine's reliability, dependability and value.

You are welcome to visit our website [www.greentec.eu](http://www.greentec.eu) - where the login via the dealer's access gives you the latest updates on instructional and part books on our entire product range.

We hope you will be pleased with your new GreenTec machine.

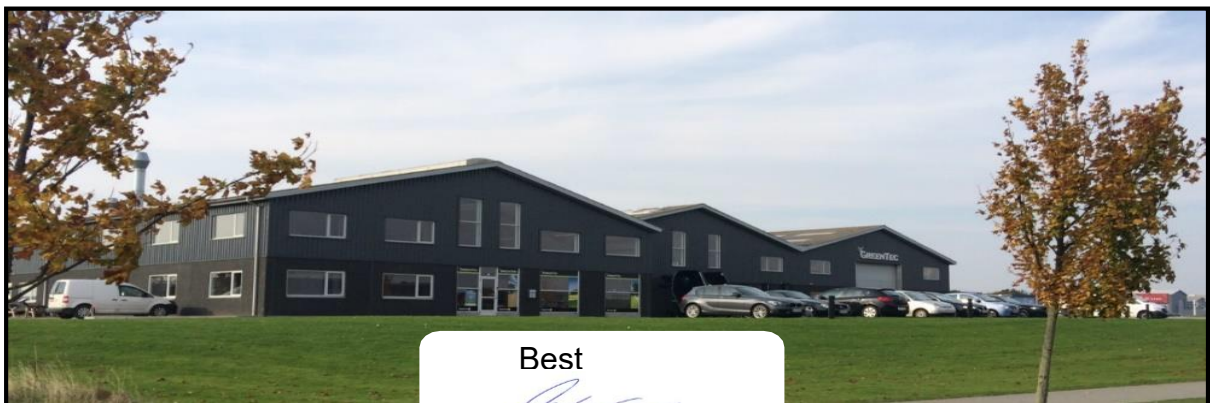

Best



John Christensen  
SalesDirector GreenTec

GreenTec's vision is to develop and sell quality machines for the maintenance of green areas, including in agriculture, in industry, at airports and in the local sector. Through innovative product development, we will strive to become a leader in our field.

All machines are developed in a simple and functional design in close cooperation with dealers and end users. It is our goal to cover every need in the market segment with preferably two different solutions. In-depth analysis of requirements and serious advice to the customer is offered the best solution, where individual needs can be met through the modularity of the product program.

Our goal is also to offer the best possible after sales service, and a quick and efficient spare parts supply.

## USEFUL INFORMATION

Before using the machine for the first time, it's the seller's responsibility that the buyer is given this parts list. If the machine is resold, the parts list must be transferred to the new owner.

Please fill out the list below to ensure that the necessary information is at hand when ordering spare parts etc.

Serial No	<input type="text"/>
Delivery date	<input type="text"/>
Dealer	<input type="text"/>
	<input type="text"/>
	<input type="text"/>
Tel/ fax	<input type="text"/>



Merkurvej 25  
DK 6000 Kolding  
Danmark  
Tel: +45 75553644  
Fax: +45 75554243  
Email: [info@greentec.eu](mailto:info@greentec.eu)  
web: [www.greentec.eu](http://www.greentec.eu)  
Opening hours: Mon-Fri 8-16

## **ORDERING PARTS**

**When ordering parts please refer to your parts list to help your dealer with your order.**

- **Part number and quantity**
- **Description**
- **Machine model number**
- **Serial number of the machine**
- **Delivery instructions (e.g. next day).**

**Delivery is normally via carrier direct to your dealer. Please check with your dealer for stock availability and arrangement of dispatch. Ensure you or your dealer has sufficient cover for parts requirement outside factory hours.**

### **Important Note:**

**The information contained in this manual is correct at the time of publication. However, in the course of constant development, changes in specification are inevitable. Should you find the information given in this book different to the machine it relates to, please contact the “After Sales Department” for advice.**

### **Key:**

**LH:**        Left hand  
**RH:**        Right hand

## SPARE PARTS

### Tiger 725 cpl.

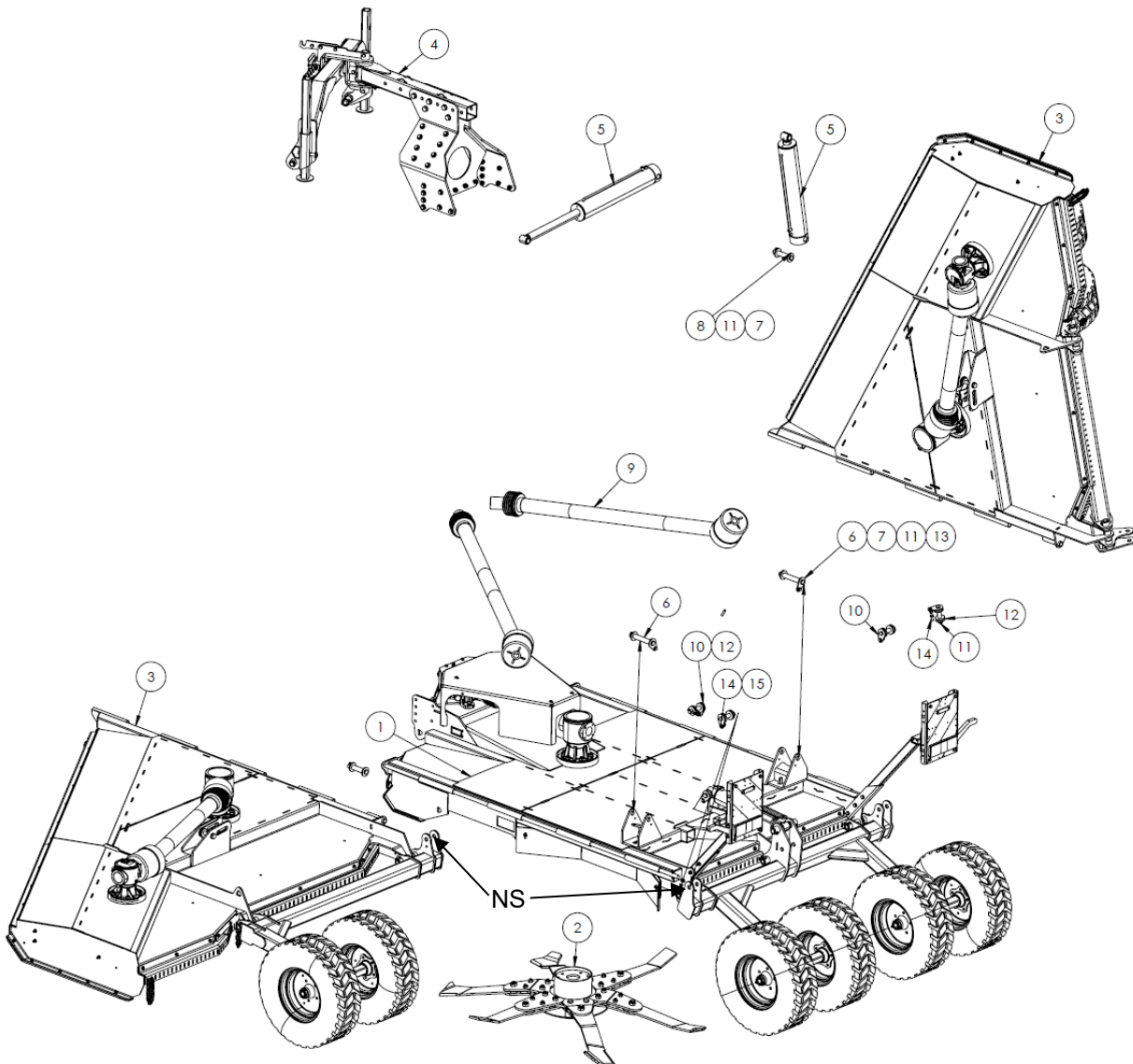

ITEM NO.	PART NUMBER	DESCRIPTION	QTY.
1		Center Body complete, see ass. drawing	1
2		Cutting head Right CCW, seen from ground, see assembly drawing	1
3		Right Wing 725, see assembly drawing	2
4		Tow link assembly, see assembly drawing	1
5	6703609	Cylinder f/Wing	2
6	6703713	Welded pin	2
7	6703698.2	Washer	4

8	6703698	Welded pin	2
9		PTO long, see assembly drawing	2
10	6703726	Pin f/link	4
11	6703602	Key	9
12	6703669	Washer	12
13	6702617	Flangebolt	2
14	6702591	Flangebolt	4
15	6701984	Flangenut	4
NS	XXX	Sealkit	
NS		Joint for wing height, see assembly drawing	2

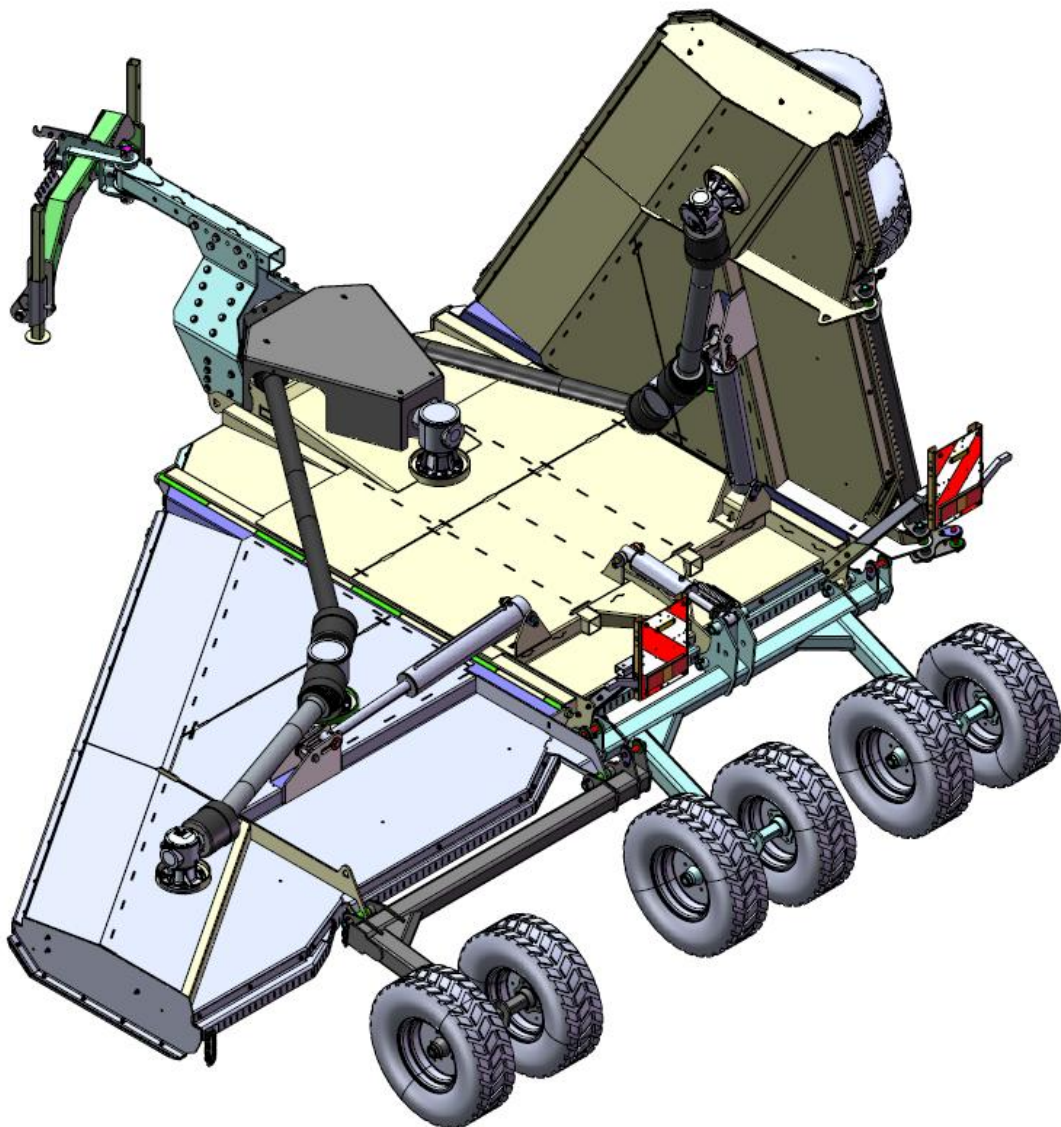

### Joint for wing height (ADGT1567)

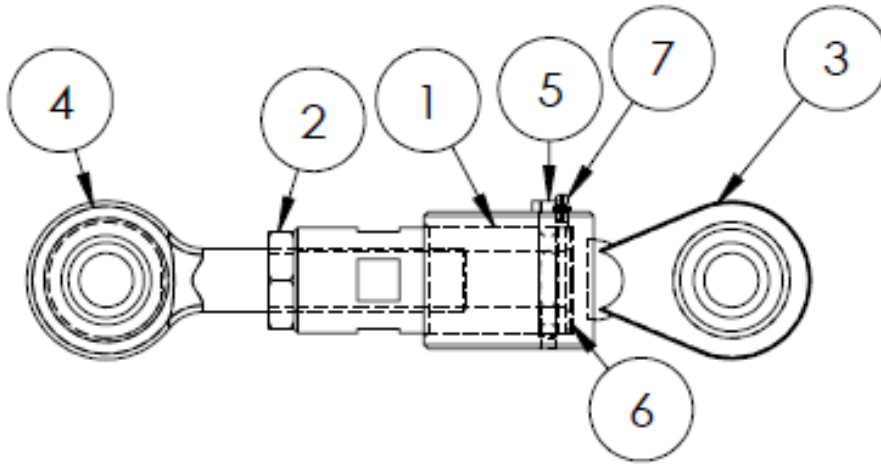

ITEM NO.	PART NUMBER	DESCRIPTION	QTY.
1	6703613	Bushing	1
2	6703614	Nut	1
3	6703612	Welded rod	1
4	6703611	Rod end	1
5	2770430	Bolt	2
6	6703615	Bearing	1
7	8222027	Greasnipple	1

### Center body cpl. (ADGT1592)

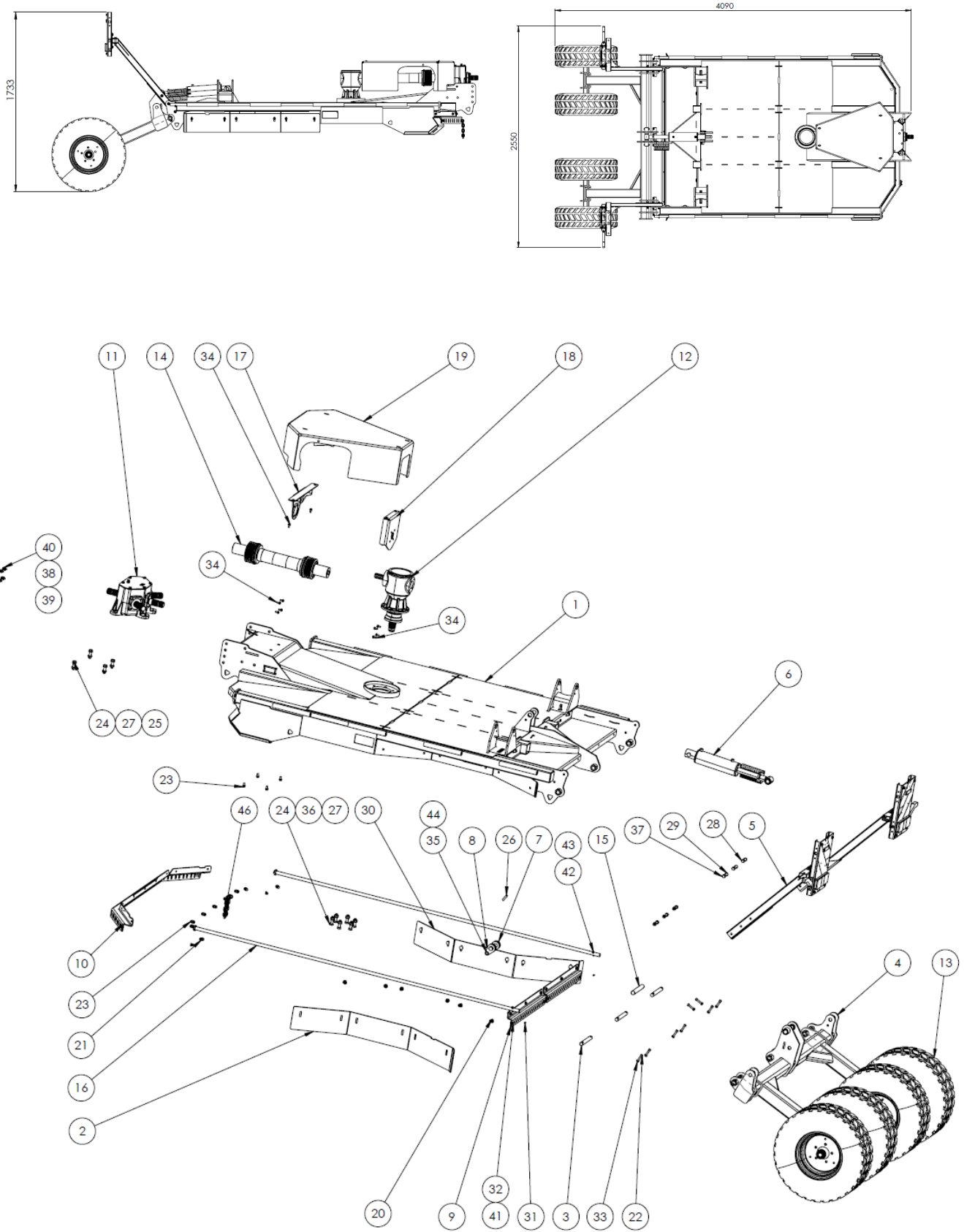

ITEM NO.	PART NUMBER	DESCRIPTION	QTY.
1	6703607	Center body	1
2	6703649L	Adjustable skirt	1
3	6703696	Pin f/axle support	3
4	6703665	Centre axle	1
5		Cpl. Rear Light support, see ass. drawing	1
6	6703608	Cylinder Lift wheel, see ass. drawing	1
7	6703698.2	Washer	3
8	6703715	Pin f/cylinder, Lift	1
9	6703625	Chain skirt, centre body rear	2
10	6703624	Chain skirt centre front	1
11	5000065	Splittergear, see assembly drawing	1
12	5000063	Centergear, see assembly drawing	1
13	6703652	Wheel with 3 drain hole	4
14		PTO, see ass. drawing	1
15	6703720	Pin f/lift	1
16	6703699	Welded hinge pin f/wing	2
17	6703724	Bracket f/guard	1
18	6703727	Bracket f/guard	1
19	6703725	Guard f/gear	1
20	8222022	Bolt	12
21	6701575	Lock nut	27
22	6703488	Bolt	8
23	6702399	Flangebolt	19
24	9040173	Bolt	10
25	6702239	Nut	4
26	6703602	Key	1
27	6701548	Washer	10
28	931120702	Bolt	2
29	6923122	Flangenut	6
30	6703649R	Adjustable skirt	1
31	8222027	Greasenipple	2
32	6703618	Wire grips	6
33	8222023	Lock nut	8
34	6702613	Flangebolt	12
35	6702591	Flangebolt	1

---

36	81822001	Lock nut	6
37	6703484	Bolt	4
38	8142007	HD washer f/PTO cover	8
39	8362011	Washer f/PTO cover	4
40	6702614	Flangebolt f/PTO cover	4
41	9040189	Lock nut	12
42	6703750	Bolt	2
43	6701629	Lock nut	2
44	6701984	Flangenut	1
45	6701641	Washer	6
46	6703617	Chain f/guard	44

**Splitter gearbox cpl.**

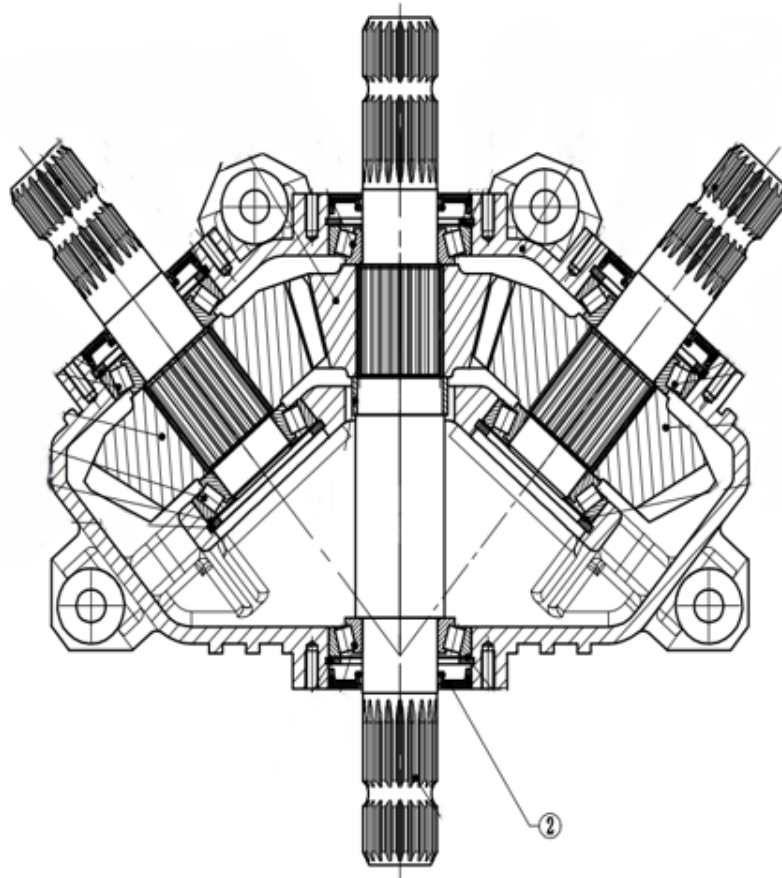

ITEM NO.	PART NUMBER	DESCRIPTION	QTY.
1	5000065	Splitter gearbox cpl	1
2	5000304	Oil seals, double-lip	4

**Outerwing gearbox cpl.**

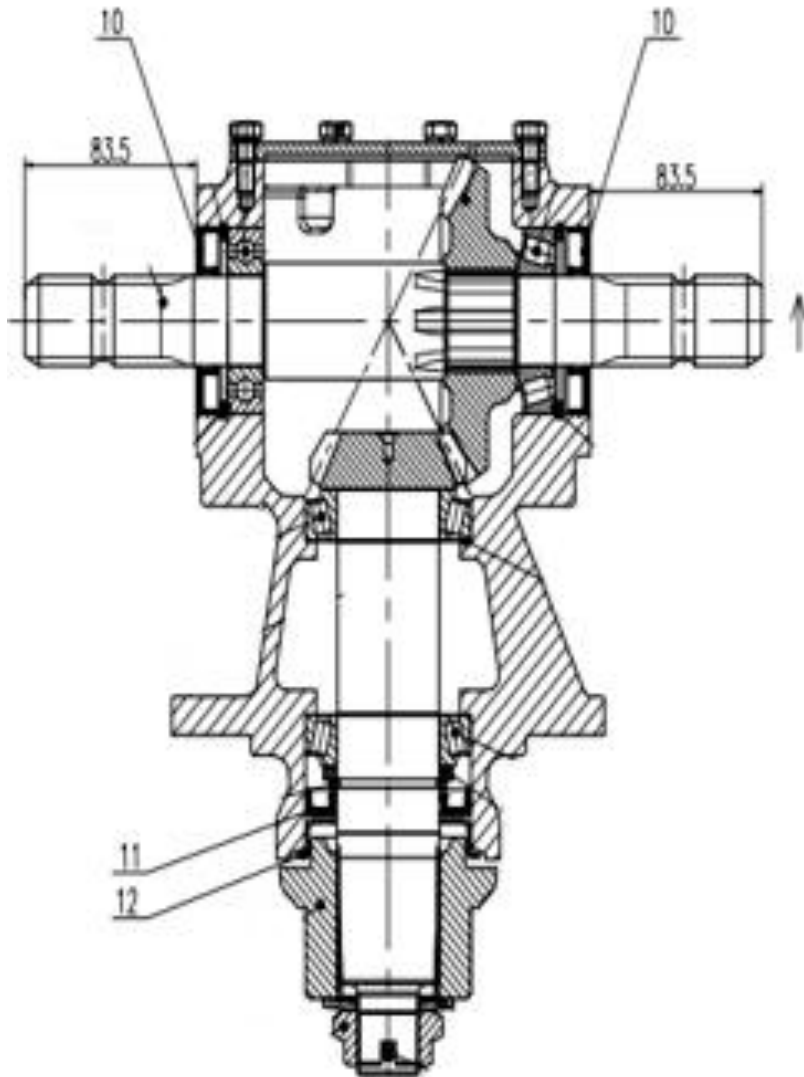

ITEM NO.	PART NUMBER	DESCRIPTION	QTY.
	5000105	Outerwing gearbox cpl	1
10	5000296	Oil seals, double lip	2
11	5000297	Oil seals, double lip	1
12	5000298	Dustcover	1

Innerwing gearbox cpl.

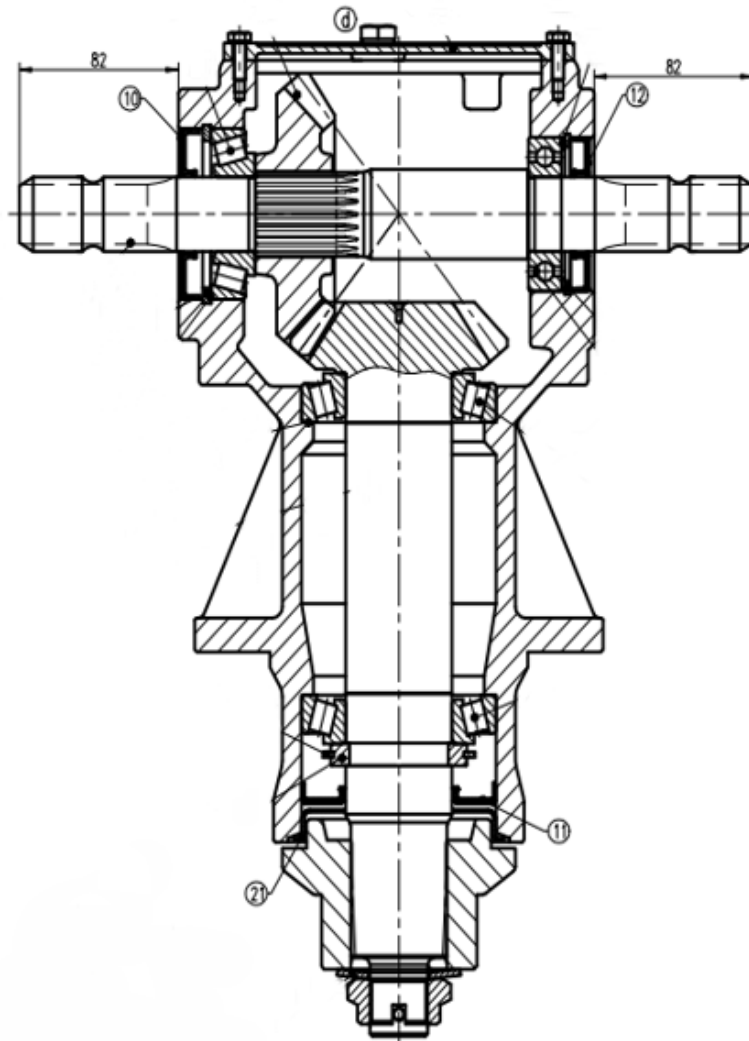

ITEM NO.	PART NUMBER	DESCRIPTION	QTY.
	5000064	Innerwing gearbox cpl	1
10	5000300	Oil seals, double lip	1
11	5000301	Oil seals, double lip	1
12	5000296	Oil seals, double lip	1
21	5000299	Dustcover	1

**Center gearbox cpl.**

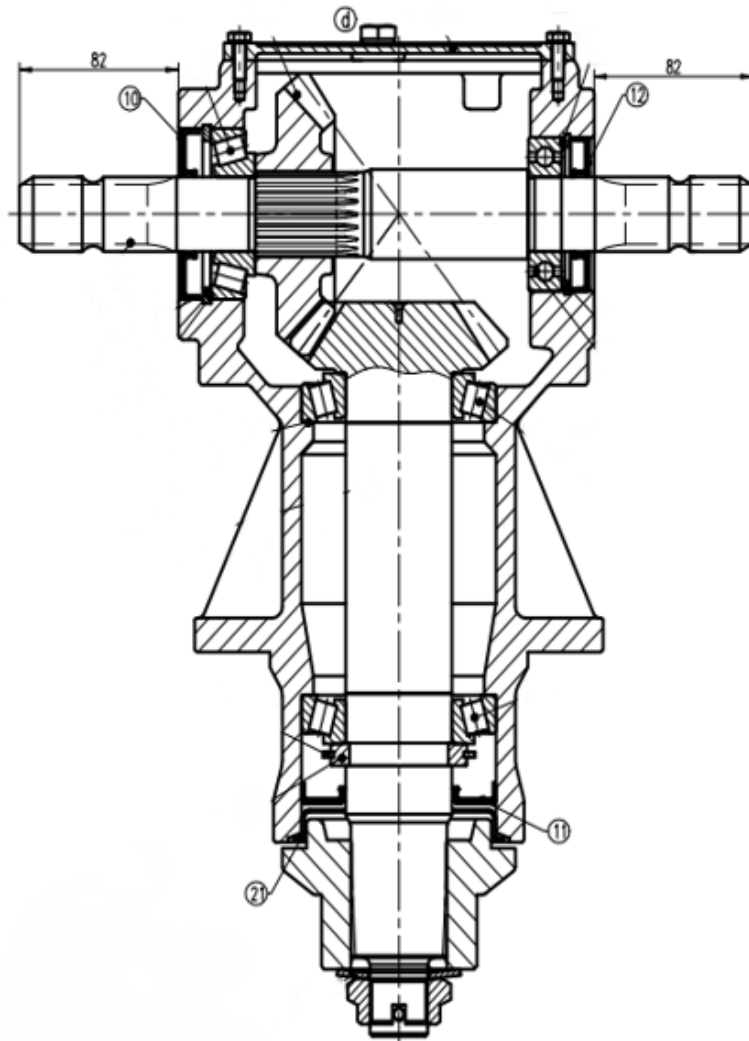

ITEM NO.	PART NUMBER	DESCRIPTION	QTY.
	5000063	Center gearbox cpl	1
10	5000300	Oil seals, double lip	1
11	5000301	Oil seals, double lip	1
12	5000303	Oil seals, solid	1
21	5000299	Dustcover	1

### Cutting head Right/Left CW/CCW cpl. (ADGT1568/1569)

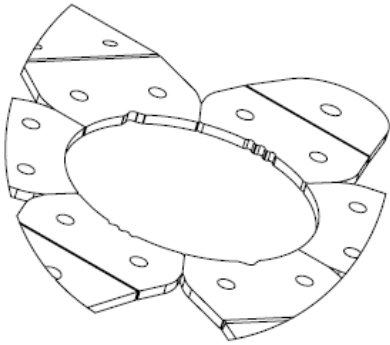

DETAIL A  
SCALE 1 : 5

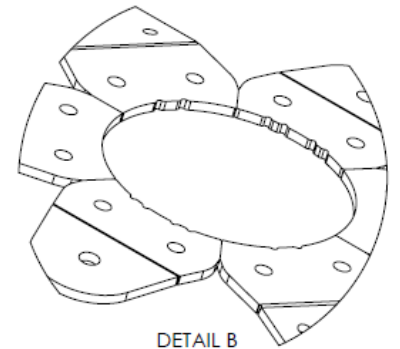
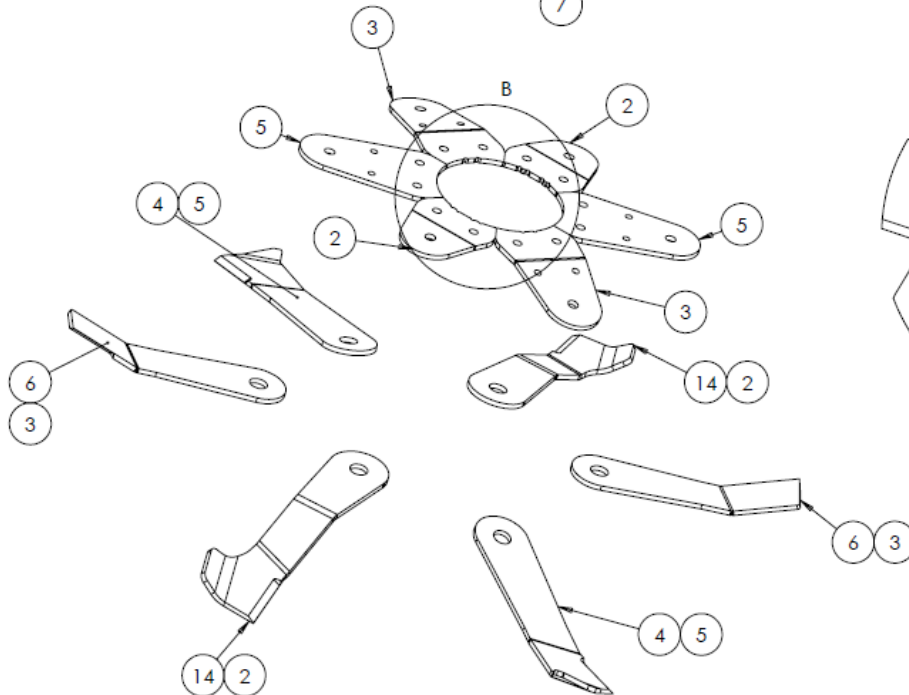
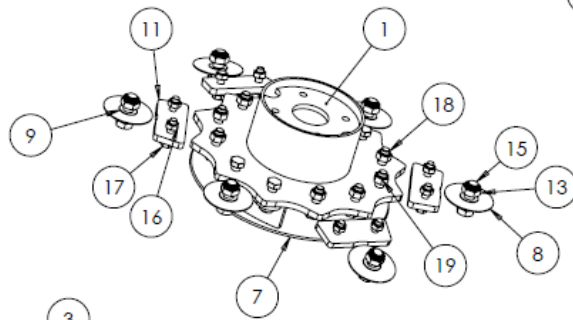
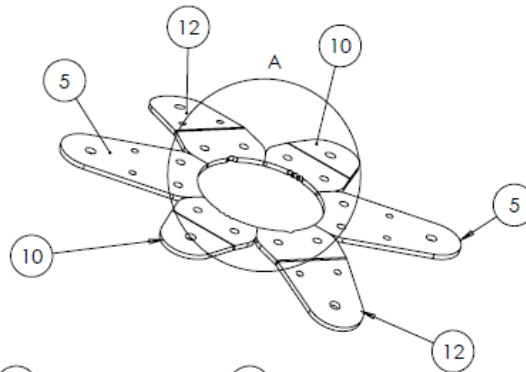

DETAIL B  
SCALE 1 : 5

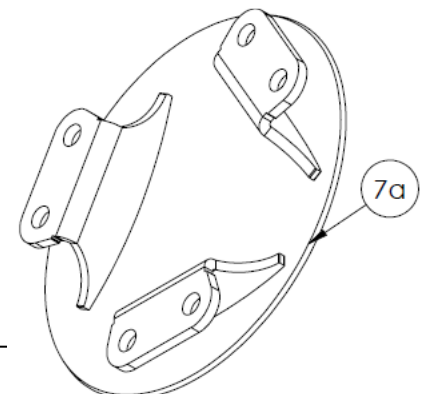

ITEM NO.	PART NUMBER	DESCRIPTION	QTY.
1	6703642	Hub f/ rotor	1
2	6703657	Short lower holder f/Blade	2
3	6703659	Holder f/Blade	2
4	6703622R/6703622L	Mulcher Blade long Right CCW	2
5	6703659	Holder main Blade	4
6	6703623R/6703623L	Recycler Blade Long Right CW	2
7	6703690	Scalp f/rotor	1
7a	6703742	Scalp f/rotor, 3 blades	1
8	6703694	Washer	6
9	6703693	Blade bush	6
10	6703691	Short Holder f/Blade	2
11	6703692	Spacer	4
12	6703695	Holder f/Blade	2
13	6701558	Locknut	6
14	6703621R/6703621L	High Lift Blade long Right CCW	2
15	6703584	Bolt	6
16	81822001	Locknut	8
17	6703689	Bolt	8
18	6703744	Bolt	12
19	9040182	Locknut	12

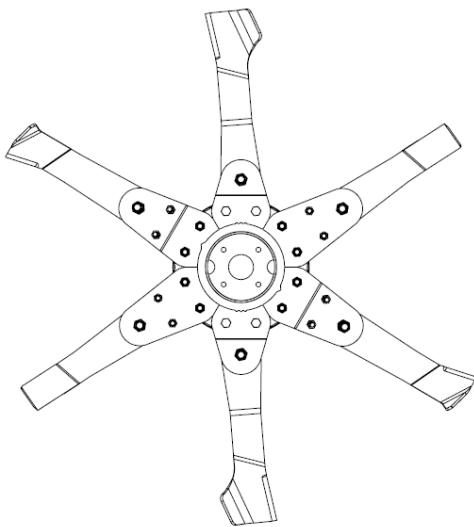

### Wing Right/Left cpl. (ADGT1580R/1580L)

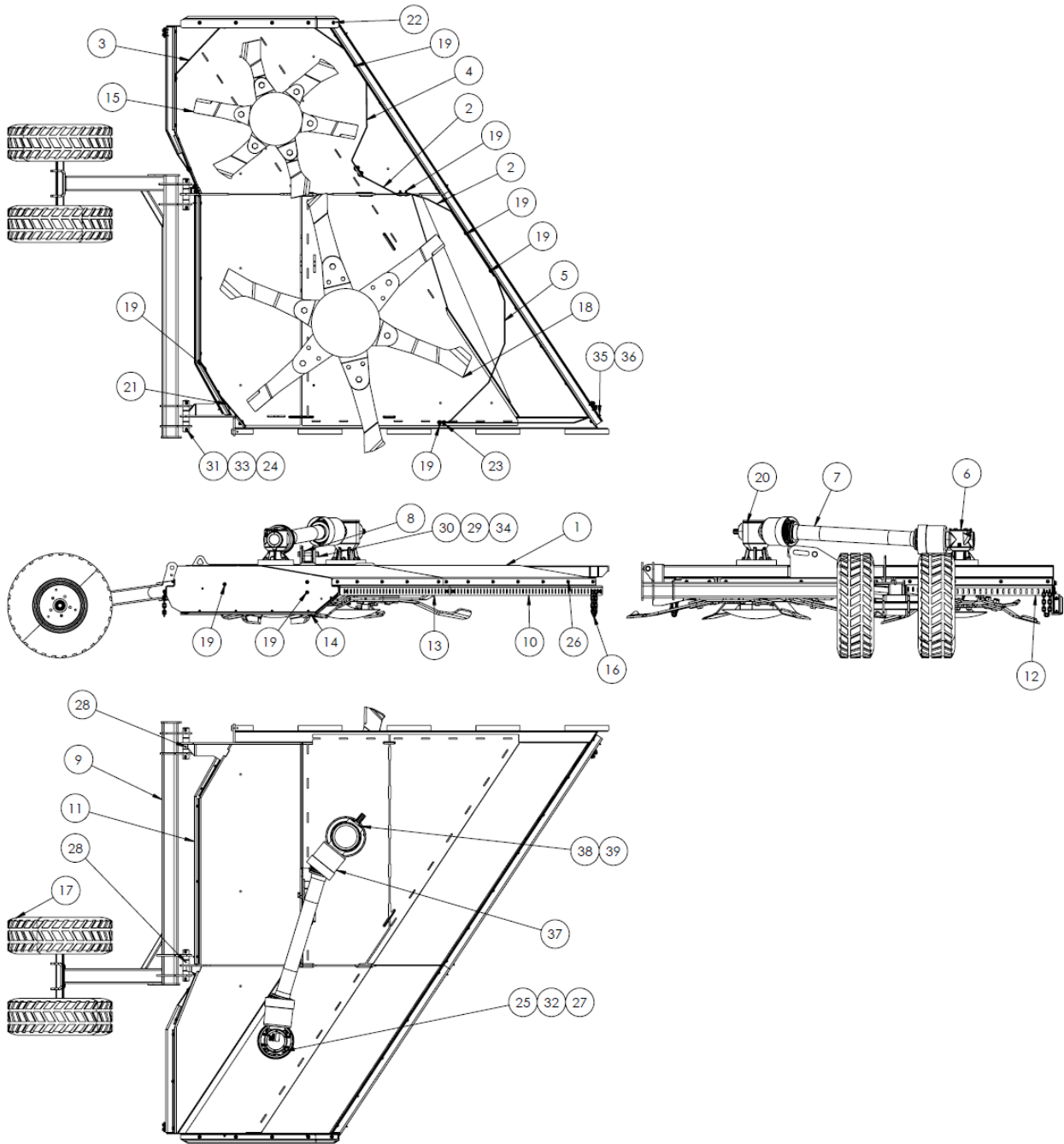

ITEM NO.	PART NUMBER	DESCRIPTION	QTY.
1	6703670R/6703670L	7m wing right/left	1
2	6703673R/6703670L	Skirt wing	1
3	6703688R/6703688L	Skirt outer wing	1
4	6703672R/6703672L	Skirt wing	1
5	6703671R/6703671L	Skirt	1
6	5000105	Gear f/outerwing, see assembly drawing	1

7		PTO, see assembly drawing	1
8	6703705	Wing locks	1
9	6703674R/6703674L	Right Wheel axle, see assembly drawing	1
10	6703737R/6703737L	Chain guard	1
11	6703740R/6703740L	Chain guard	1
12	6703734R/6703734L	Chain guard welded	1
13	6703735R/6703735L	Chain guard	1
14	6703736R/6703736L	Wear plate	1
15		725 outer wing rotor CW, see assembly drawing	1
15a		725 outer wing rotor CCW, see assembly drawing	1
16	6703617	Chain guard 15 Links	74
17	6703652	Wheel with 3 drain hole	2
18		Cutting head right CW, see assembly drawing	1
18a		Cutting head right CCW, see assembly drawing	1
19	2770257	Bolt	14
20	5000064	Gear f/innerwing, see assembly drawing	1
21	6703738R/6703738L	Skirt wing	1
22	6701871	Bolt	5
23	6701575	Locknut	35
24	6703696	Pin f/axle support	2
25	9040173	Bolt	10
26	6702399	Flangebolt	16
27	81822001	Locknut	10
28	8222027	Greasenipple	2
29	6703751	Bolt	1
30	9040182	Locknut	1
31	6703488	Bolt	4
32	6701548	Washer	10
33	8222023	Locknut	4
34	9040183	Washer	2
35	9040189	Locknut	16
36	6703618	Wire grips	8
37	6703718	Cone	2
38	6702613	Flangebolt	12
39	8362011	Washer	12

## Outer wing rotor CW/CCW cpl. 6 blades (ADGT1578/1579)

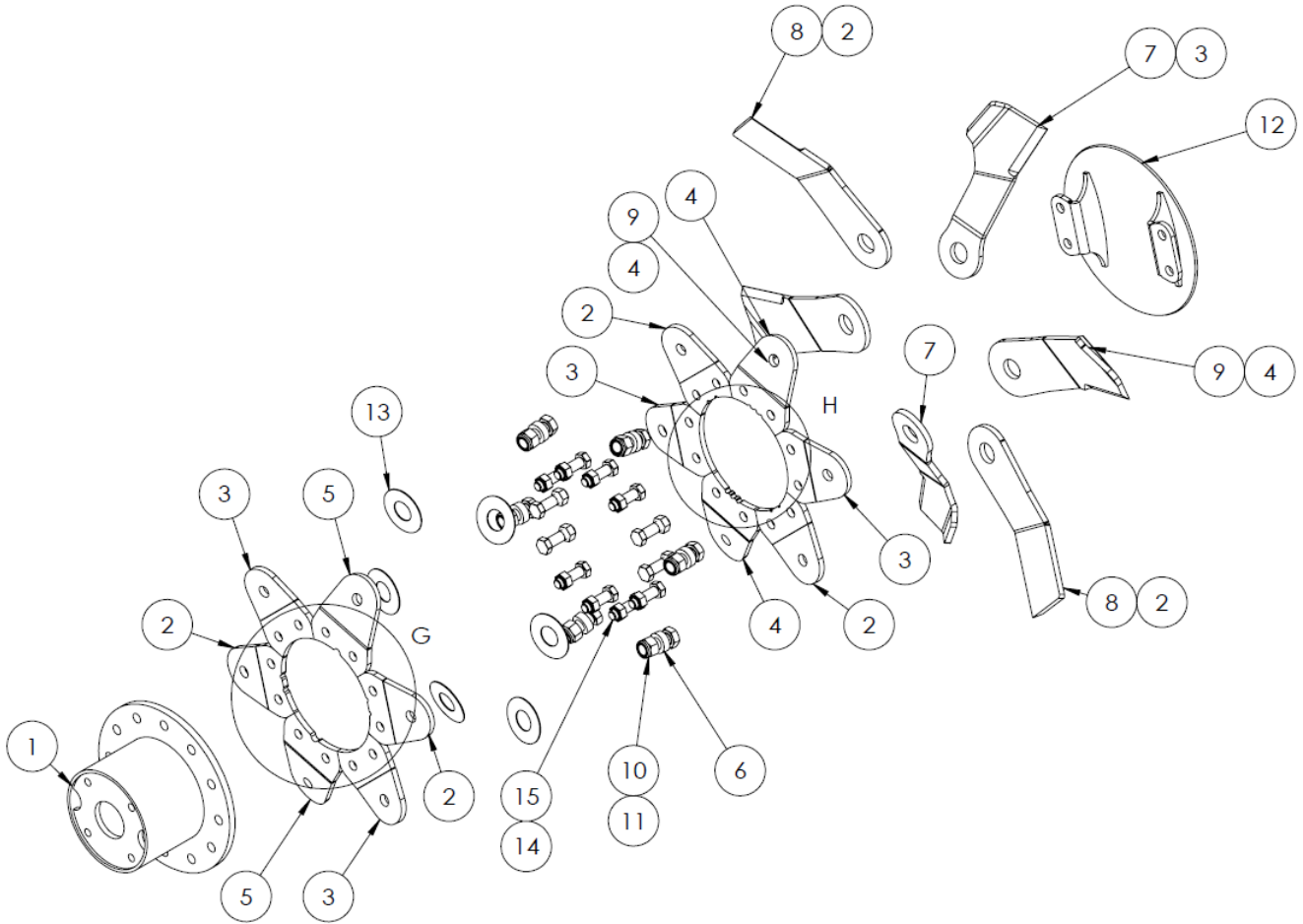

ITEM NO.	PART NUMBER	DESCRIPTION	QTY.
1	6703675	Hub	1
2	6703662	Holder balde	4
3	6703664	Holder blade	4
4	6703661	Holder blade	2
5	6703660	Holder blade	2
6	6703693	Blade bush	6
7	6703676R/6703676L	High Lift Blade Short Right/Left CCW/CW	2
8	6703678R/6703678L	Recycler Blade short Right/Left CCW/CW	2
9	6703677R/6703677L	Mulcher Blade Short Right/Left CCW/CW	2
10	6701558	Locknut	6
11	6703584	Bolt	6
12	6703666	Scalp f/rotor 6 blades	1
13	6703668	Washer	6
14	9040182	Locknut	12
15	6703744	Bolt	12

## Outer wing rotor CW/CCW cpl. 3 blades (ADGT1582R/1582L)

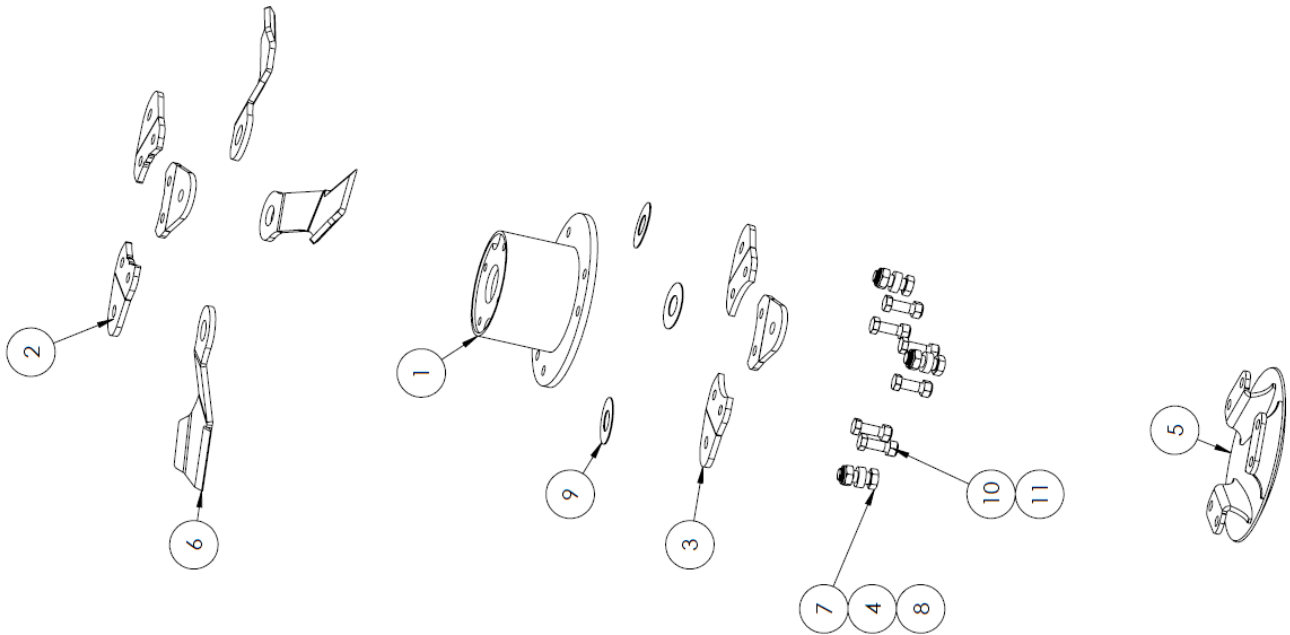

ITEM NO.	PART NUMBER	DESCRIPTION	QTY.
1	6703645	Hub	1
2	6703662	Holder blade	3
3	6703664	Holder blade	3
4	6703693	Blade bush	3
5	6703742	Scalp f/rotor, 3 blades	1
6	6703676R/6703676L	High Lift Blade Short Right/Left CCW/CW	3
7	6703584	Bolt	3
8	6701558	Locknut	3
9	6703668	Washer	3
10	9040182	Locknut	6
11	6703744	Bolt	6

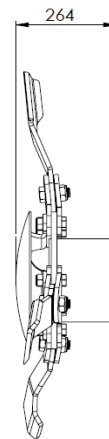
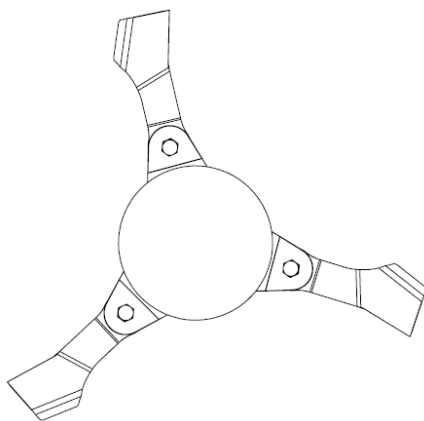

## Light cpl. Right/Left (ADGT1589R/1589L)

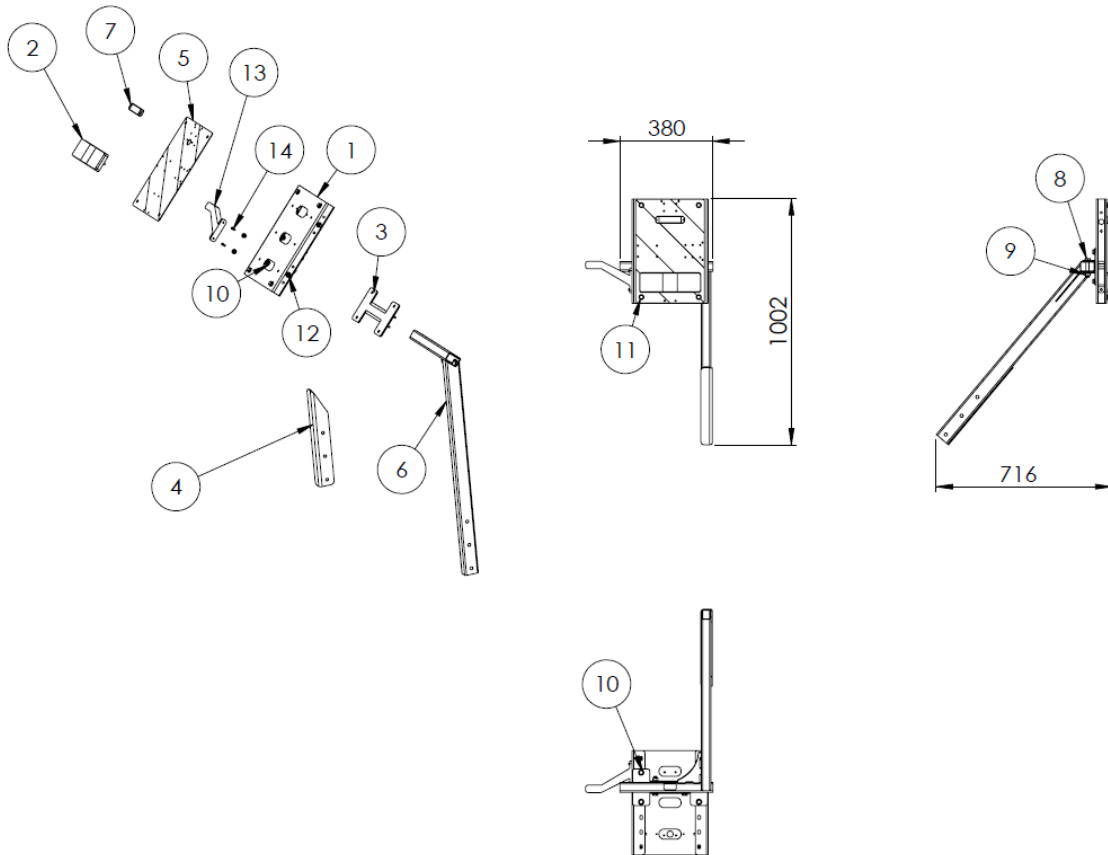

ITEM NO.	PART NUMBER	DESCRIPTION	QTY.
1	6703706	Light board	1
2	6703710R/6703710L	Rear light	1
3	6703707	Bracket f/light	1
4	6703708R/6703708L	Holder f/light support	1
5	6703712R/6703712L	Reflector board	1
6	6703709R/6703709L	Rear light support	1
7	6703714	Led Beacon	1
8	931120702	Bolt	2
9	6701984	Flangenut	2
10	6703790	Flangebolt	4
11	6702399	Flangebolt	4
12	6701575	Locknut	8
13	6703749R/6703749L	Clearance light Right/Left	1
14	6703748	Bolt	2
15	6701569	Nut	2

## Top link R/L cpl. (ADGT1571)

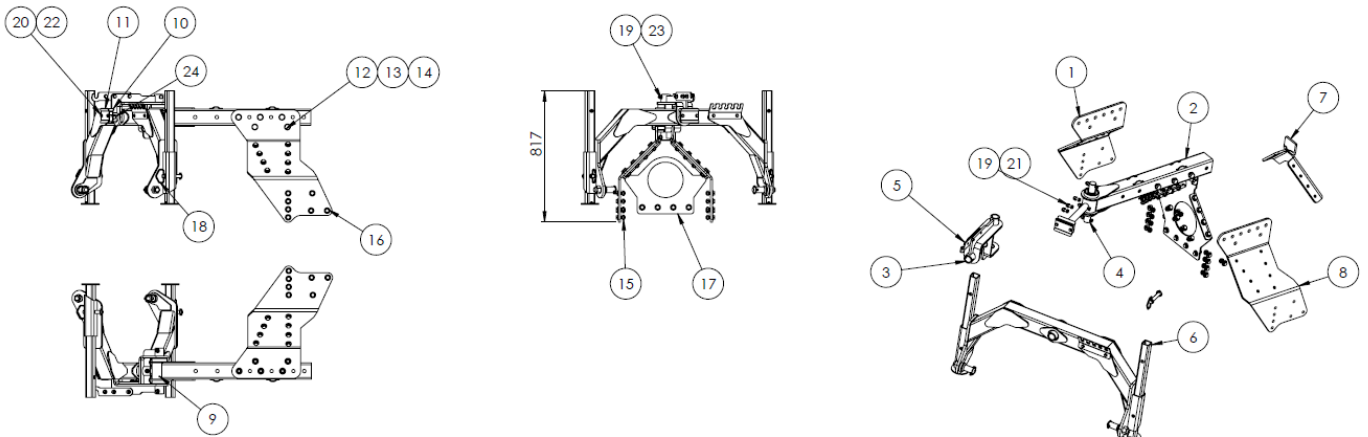

ITEM NO.	PART NUMBER	DESCRIPTION	QTY.
1	6703648R	Hitch side plate Right	1
2		Tow link, see assembly drawing	1
3	6703645	Hitch knuckle	1
4	6703646	Pin f/tow bar	1
5	6703650	Hook, towlink	1
6		Linkage frame, see assembly drawing	1
7	6703647	Welding cable tie	1
8	6703648L	Hitch side plate Left	1
9	8222027	Greasenipple	1
10	6703681	Hose holder	1
11	6703682	Hose holder	1
12	931201502	Bolt	5
13	9040183	Washer	10
14	9040182	Locknut	5
15	6702239	Nut	34
16	6703686	Flangebolt	34
17	6703687	Linkage brace plate	1
18	6310215	Pin with handle	2
19	6701984	Flangenut	7
20	6703743	Flangebolt	2
21	6702591	Flangebolt	3
22	9040190	Locknut	2
23	6703485	Bolt	3
24	5770491.01	Bolt	1

# PTO inner wing cpl. (ADGT1590)

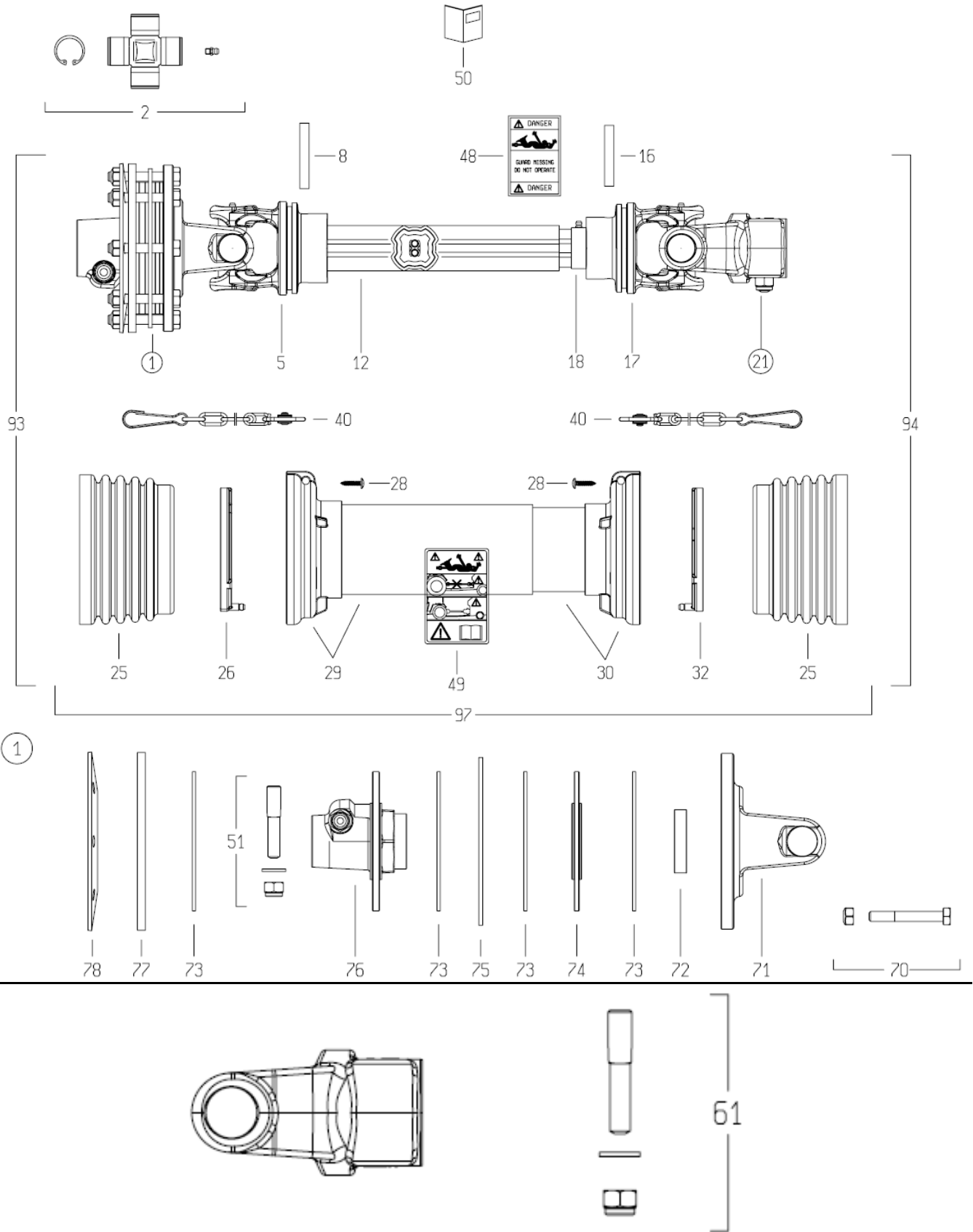

ITEM NO.	PART NUMBER	DESCRIPTION	QTY.
1	5000210	Taper pin	1
2	5000211	Cross Kit	2
5	5000212	Tube yoke	1
8	5000213	Spring roll	1
12	5000214	Drive tube	1
16	5000215	Spring roll	1
17	6703499	Tube yoke	1
18	5000216	Cardan tube	1
21	5000217	Yoke	1
25	5000218	Cone shield bell	2
26	5000219	Shield support	1
28	5000220	Screw self tap	6
29	5000221	Shield outer tube+cone	1
30	5000222	Shield outer tube+cone	1
32	5000223	Shield support inner	1
40	5000224	Shield chain L=500	2
48	5000225	Label Danger – outer drive tube	1
49	5000226	Label Danger – outer shield	1
50	5000227	Instruction book	1
51	5000228	Taper pin	1
61	5000229	Taber pin kit	1
70	5000230	Screw hex head	8
71	5000231	Flange yoke	1
72	5000232	Bushing	1
73	5000233	Lining	4
74	5000241	Driving disc	1
75	5000234	Clutch inner plate	1
76	5000235	Hub – Tuber pin	1
77	5000236	Pressure plate	1
78	5000237	Belleville spring	1
93	5000238	Outer half shaft	1
94	5000239	Inner half shaft	1
97	5000240	Complete safety kit	1

# PTO outer wing cpl. (ADGT1581)

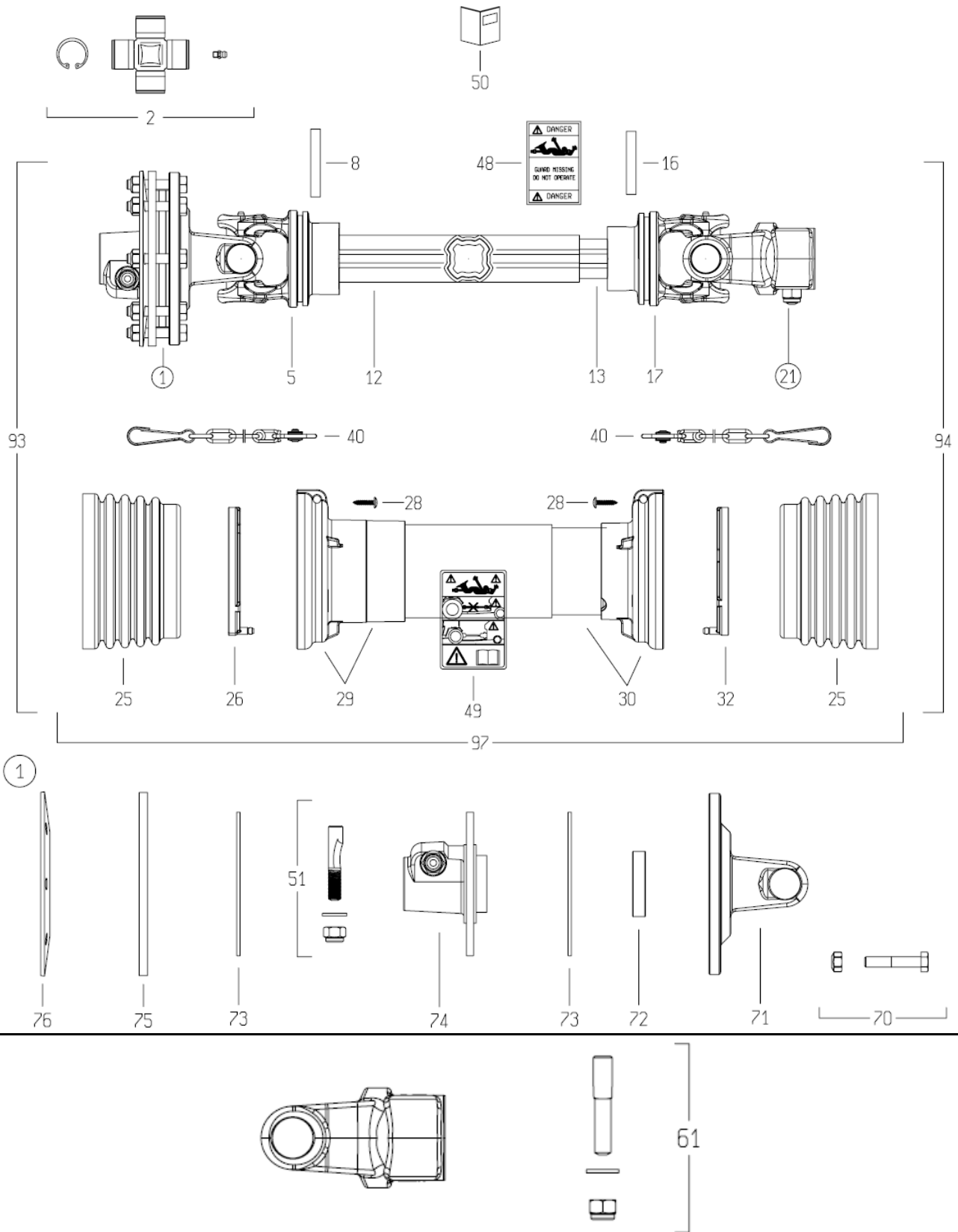

ITEM NO.	PART NUMBER	DESCRIPTION	QTY.
1	5000260	Taper pin	1
2	5000211	Cross Kit	2
5	5000212	Tube yoke	1
8	5000213	Spring roll	1
12	5000261	Cardan tube L=760	1
13	5000262	Inner cardan tube	1
16	5000215	Spring roll pin	1
17	6703499	Tube yoke	1
21	5000217	Yoke	1
25	5000218	Cone shield bell	2
26	5000219	Shield support	1
28	5000220	Screw self tap	6
29	5000263	Shield outer tube+cone	1
30	5000264	Shield inner tube+cone	1
32	5000223	Shield support inner	1
40	5000224	Shield chain L=500	2
48	5000225	Label Danger – outer drive tube	1
49	5000226	Label Danger – outer shield	1
50	5000227	Instruction book	1
51	5000265	Taper pin	1
61	5000229	Taber pin kit	1
70	5000266	Screw hex head	8
71	5000231	Flange yoke	1
72	5000232	Bushing	1
73	5000233	Lining	4
74	5000267	Hub	1
75	5000236	Pressure plate	1
76	5000237	Belleville spring	1
93	5000268	Outer half shaft driveline	1
94	5000269	Inner half shaft driveline	1
97	5000270	Complete safety kit	1

# PTO centre shaft cpl. (ADGT1591)

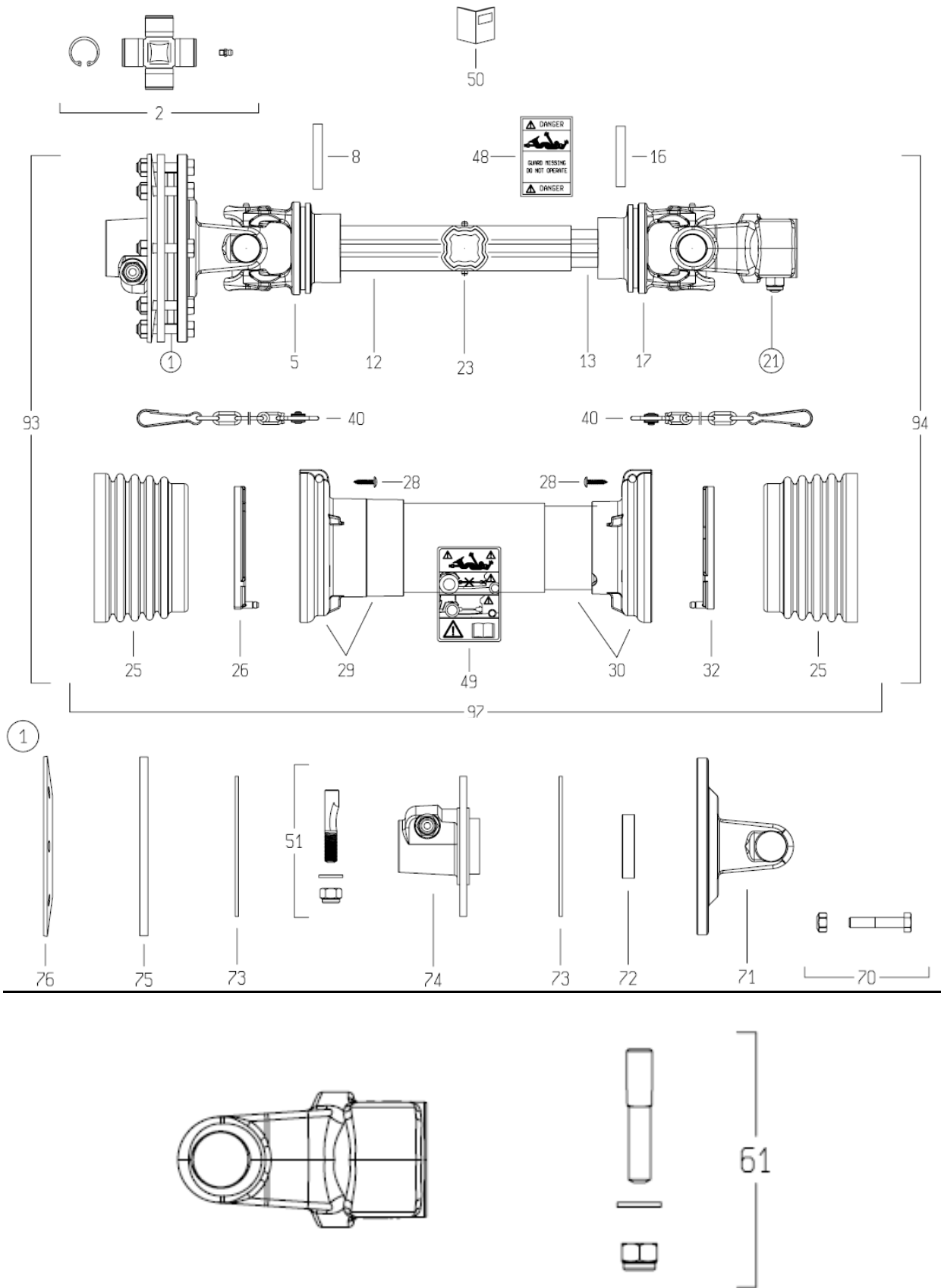

ITEM NO.	PART NUMBER	DESCRIPTION	QTY.
1	5000242	Taper pin	1
2	5000211	Cross Kit	2
5	5000212	Tube yoke	1
8	5000213	Spring roll	1
12	5000243	Cardan tube L=240	1
13	5000244	Inner cardan tube	1
16	5000245	Spring roll pin	1
17	6703499	Tube yoke	1
21	5000246	Yoke	1
23	5000247	Grease fitting	2
25	5000218	Cone shield bell	2
26	5000219	Shield support	1
28	5000220	Screw self tap	6
29	5000248	Shield outer tube+cone	1
30	5000249	Shield inner tube+cone	1
32	5000223	Shield support inner	1
40	5000224	Shield chain L=500	2
48	5000225	Label Danger – outer drive tube	1
49	5000226	Label Danger – outer shield	1
50	5000227	Instruction book	1
51	5000250	Taper pin	1
61	5000229	Taber pin kit	1
70	5000251	Screw hex head	8
71	5000252	Flange yoke	1
72	5000232	Bushing	1
73	5000253	Lining	4
74	5000254	Hub	1
75	5000255	Pressure plate	1
76	5000256	Belleville spring	1
93	5000257	Outer half shaft driveline	1
94	5000258	Inner half shaft driveline	1
97	5000259	Complete safety kit	1

# PTO Input shaft

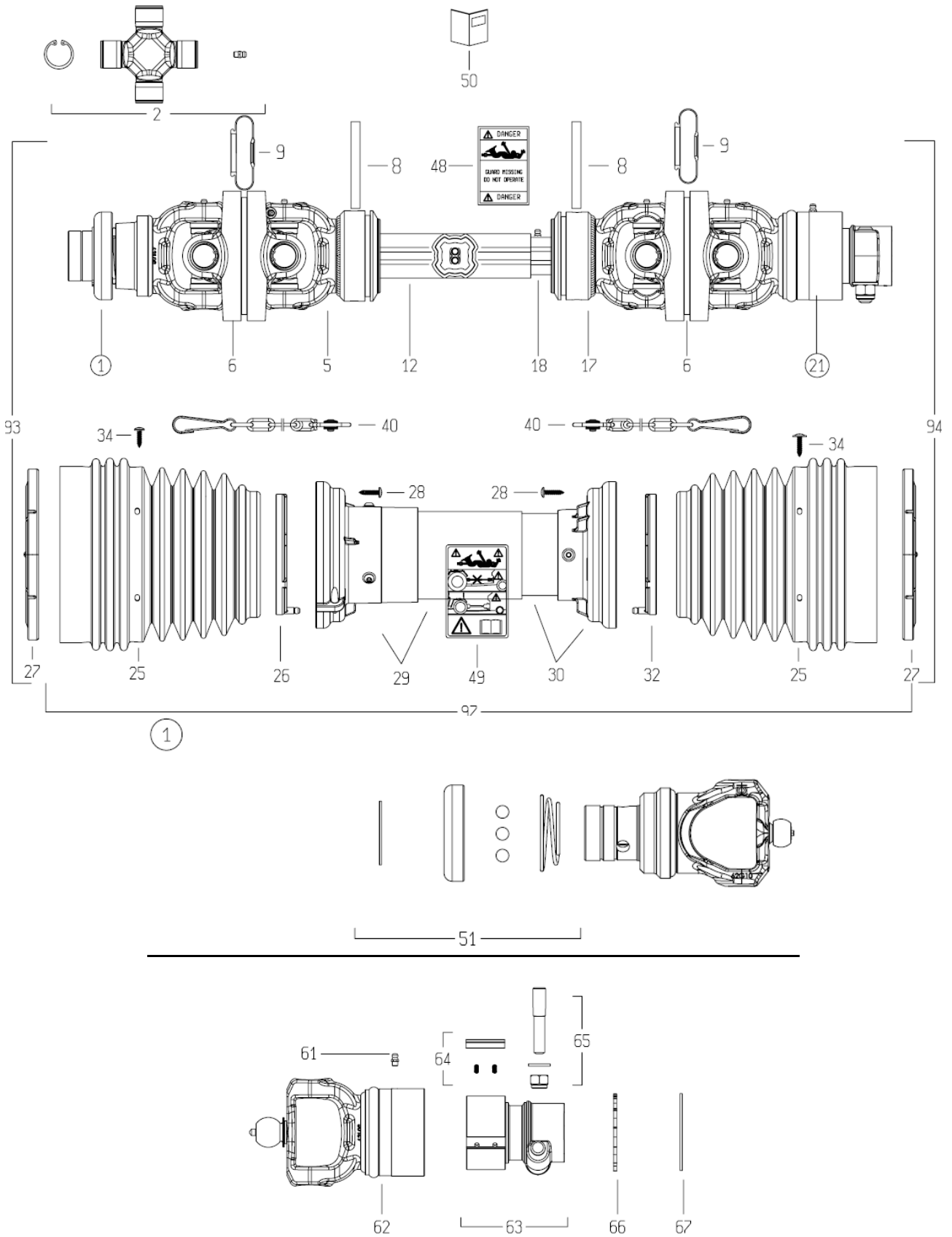

ITEM NO.	PART NUMBER	DESCRIPTION	QTY.
	OPTE5010	Comp. PTO 1-3/8-6 not	1
	OPTE5011	Comp. PTO 1-3/8-21 not	1
	OPTE5012	Comp. PTO 1-3/4-20 not	1
	OPTE5010	Comp. PTO 1-3/8-6 not to drawbar	1
	OPTE5011	Comp. PTO 1-3/8-21 not to drawbar	1
	OPTE5012	Comp. PTO 1-3/4-20 not to drawbar	1
1	5000271	Yoke 1-3/8, 6 not	1
a	XXX	Yoke 1-3/8, 21 not	1
b	XXX	Yoke 1-3/4-20 not	1
2	5000272	Cross Kit	4
5	5000273	Tube yoke	1
6	5000274	Body	2
8	5000275	Spring roll	1
9	5000276	Boot rubber	2
12	5000277	Outer tube	1
17	5000278	Tube yoke	1
18	5000279	Greasing system	1
21	5000280	Overrunning clutches	1
25	5000281	Cone shield bell	2
26	5000219	Shield support outer	1
27	5000282	Shield support	2
28	5000220	Screw self tap	6
29	5000283	Shield outer tube+cone	1
30	5000284	Shield inner tube+cone	1
32	5000223	Shield support inner	1
34	5000285	Screw self tap	12
40	5000224	Shield chain L=500	2
48	5000225	Label Danger – outer drive tube	1
49	5000226	Label Danger – outer shield	1
50	5000227	Instruction book	1
51	5000286	Ball collar kit	1
61	5000287	Grease fitting	1
62	5000288	Clutch housing	1
63	5000289	Hub	1
64	5000290	Pawl w/spring	1
65	5000250	Taber pin	1

66	5000291	Screening ring split	2
67	5000292	Circlip	1
93	OPTE5010.1	Half shaft PTO 1-3/8-6 not	1
a	OPTE5011.1	Half shaft PTO 1-3/8-21 not	1
b	OPTE5012.1	Half shaft PTO 1-3/4-20 not	1
c	OPTE5010.1	Half shaft PTO 1-3/8-6 not to drawbar	1
d	OPTE5011.1	Half shaft PTO 1-3/8-21 not to drawbar	1
d	OPTE5012.1	Half shaft PTO 1-3/4-20 not to drawbar	1
94	5000294	Inner half shaft driveline	1
97	5000295	Complete safety kit	1

### Cylinder main lift ram

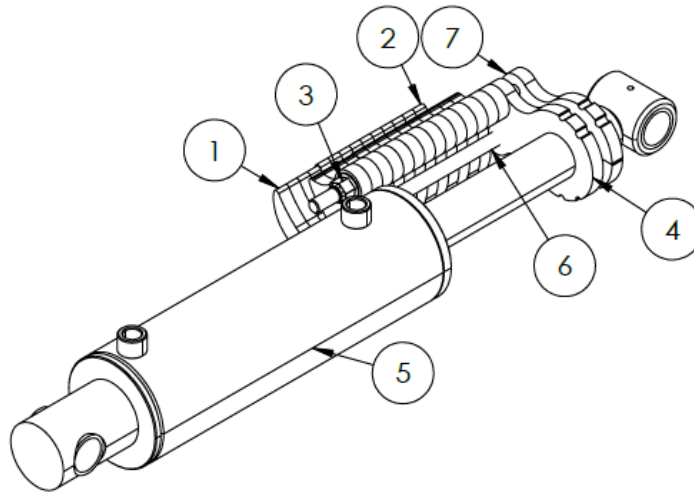

Pos 7 can be used instead of pos 4, if welded on a finalized cylinder

ITEM NO.	PART NUMBER	DESCRIPTION	QTY.
	6703608	Cylinder lift wheel cpl	
1	6703608.13	Ram spacer (closer hole)	7
2	6703608.4	Ram spacer	7
3	6701984	Flangenut	1
4	6703608.3	Rod stop	1
5	6703820	Cylinder	1
6	6703608.14	Pin	2
7	6703608.15	Rod stop	2
NS	XXX	Sealkit	

### Cylinder for wing

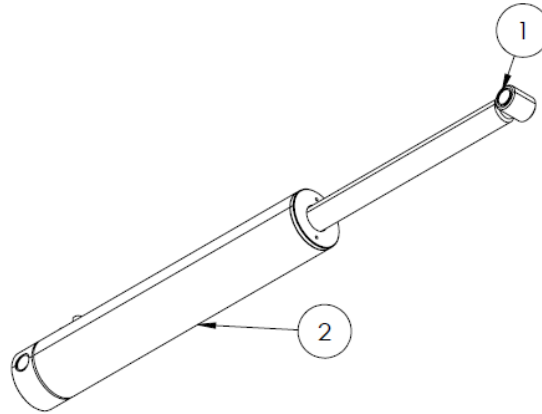

ITEM NO.	PART NUMBER	DESCRIPTION	QTY.
1	6703711	Bushing	2
2	6703609	Cylinder	1
NS	XXX	Sealkit	

### Wing axle Right/Left cpl.

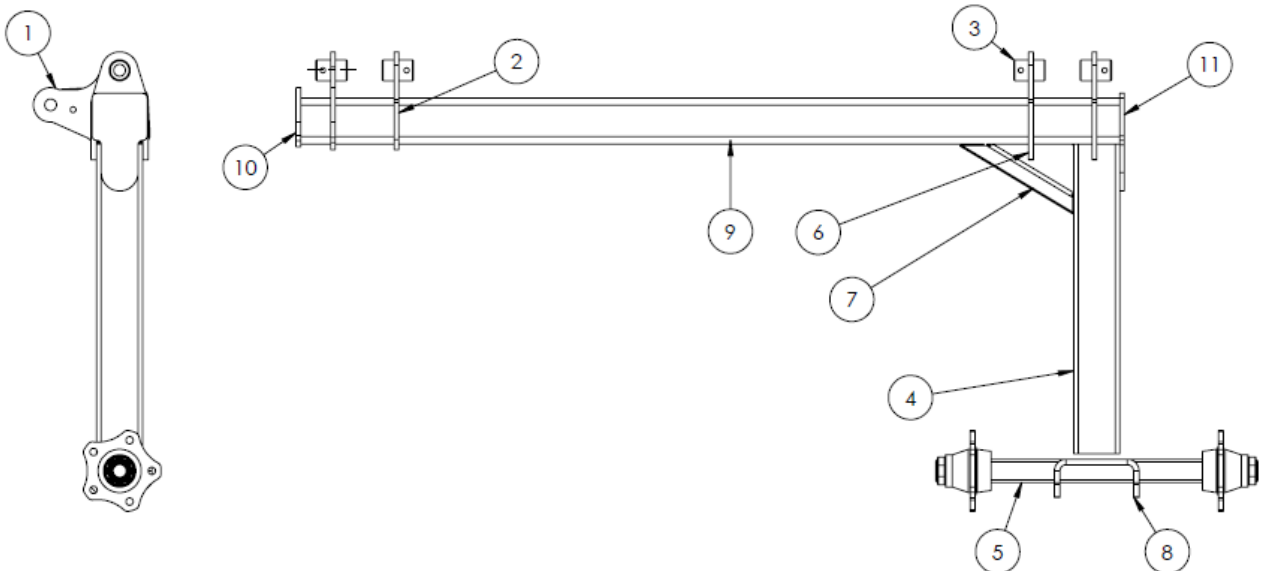

ITEM NO.	PART NUMBER	DESCRIPTION	QTY.
	6703674R/6703674L	Wing axle cpl. Right/Left	
5	6703620.9	Stub axle, twin axle (dummy)	1

## Wheel axle

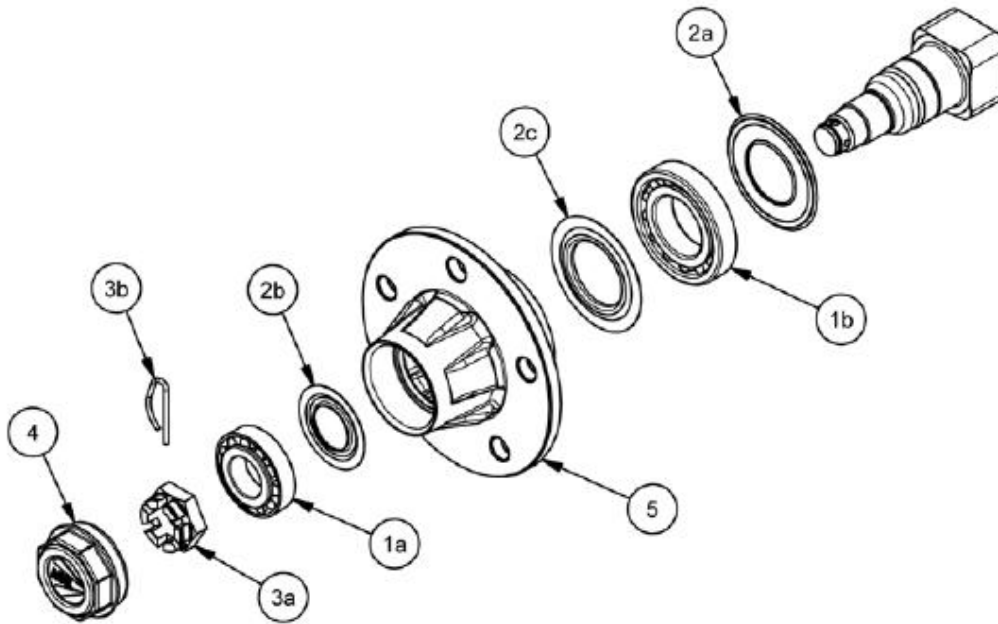

ITEM NO.	PART NUMBER	DESCRIPTION	QTY.
1a	5000200	Bearing	1
1b	5000201	Bearing	1
2a	5000202	Oil seal	1
2b	5000203	Nilos	1
2c	5000204	Nilos	1
3a	5000205	Crown nut	1
3b	5000206	Pin	1
4	5000207	Cap	1
5	5000208	Hub 5 holes	1

### Tow link (ADGT1588)

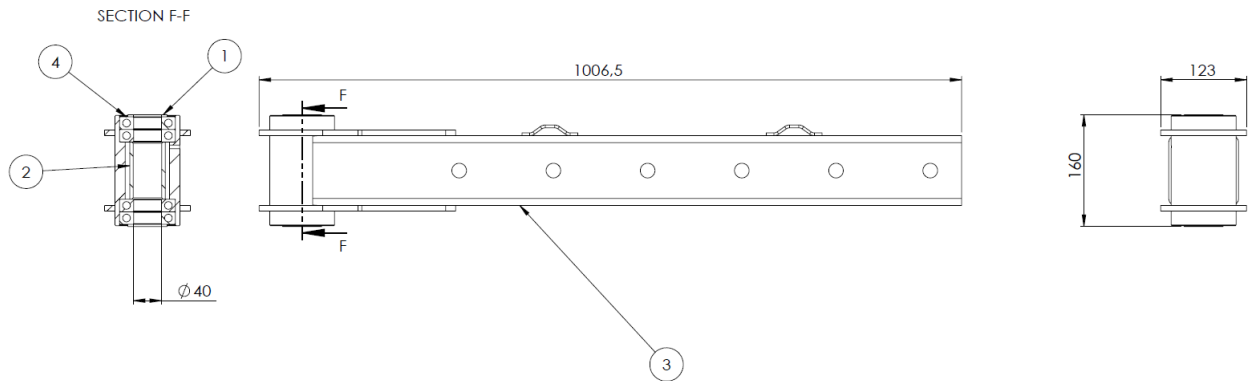

ITEM NO.	PART NUMBER	DESCRIPTION	QTY.
1	6703655	Washer	2
2	6703656	Distance bush	1
3	6703654	Tow link	1
4	6703654.4	Bearing	4

### Linkage frame (ADGT1570)

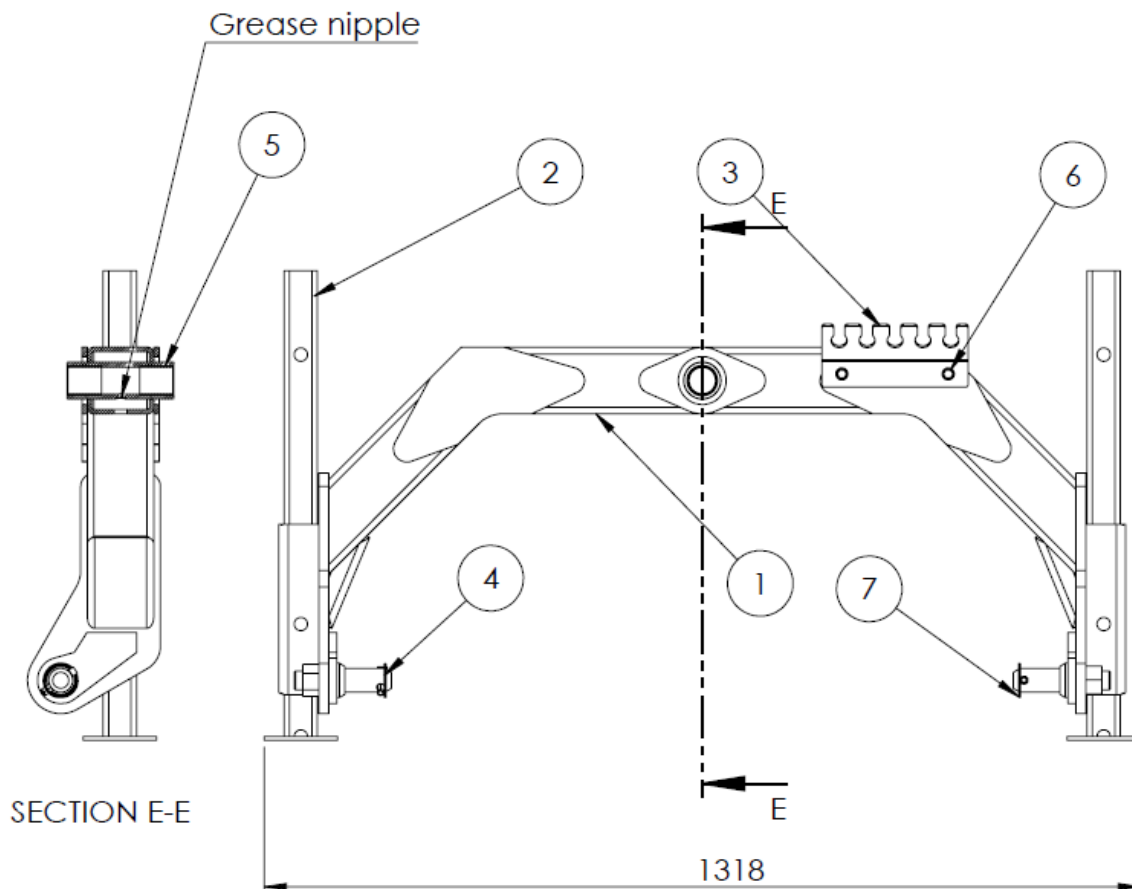

ITEM NO.	PART NUMBER	DESCRIPTION	QTY.
1	6703461	Front Support	1
2	6703640	Leg for front	2
3	6703653	Holder for hoses	1
4	6703722	Lower Link	2
5	6703716	Bush	2
6	6702613	Flangebolt	2
7	9040213	Split	2
	8222027	Grease nipple	1
NS	6310215	Pin	2

## Stickers



NO.	PART NUMBER	DESCRIPTION	QTY.
1	6703878	Stickers kit	1



Merkurvej 25 | DK-6000 Kolding | Tel.: +45 75 55 36 44 | [info@GreenTec.eu](mailto:info@GreenTec.eu) | [www.GreenTec.eu](http://www.GreenTec.eu)

*Cutting Edge Technology*