

SCORPION 4 S/PLUS

490



PARTS

UK

1st Edition 2026

 **GREENTEC**

Cutting Edge Technology



IMPORTANT INFORMATION**GreenTec**
Scorpion 490-4 S&P**PARTS**
1. Edition – 2026

NOTICE: Please ensure that this manual is handed to the operator before using the machine for the first time. If the machine is resold, the Parts list must be given to the new owner!

The information contained in this Parts list is correct at the time of publication. However, in the course of constant development, changes in specification are inevitable. Should you find the information given in this book different to the machine it relates to please contact the “After Sales Department” for advice.



Merkurvej 25
DK 6000 Kolding
Denmark
Tel: +45 75553644
E-mail: info@greentec.eu
web: www.greentec.eu

Introduction	4
Useful information	5
Ordering parts	6
Spare Part	7
Scorpion 490-4 S&P cpl. Right/Left.....	7
Scorpion 490-4 S&P main frame R/L (ADGT1505R/ADGT1505L).....	9
Scorpion 490-4 S&P tower R/L (ADGT1504R/ADGT1504L).....	10
Scorpion 490-4 S&P hose for greasing (ADGT1198) måske ny.....	11
Scorpion 490-4 S&P lift arm (ADGT1516).....	12
Scorpion 490-4 S&P swivel arm (ADGT1515R/1515L).....	13
Scorpion 490-4 S&P counterweight (ADGT1513).....	14
Scorpion 490-4 S&P cpl. tank (ADGT1508R/L).....	15
Scorpion 490-4 S&P splitterblock rear-frontmount (ADGT1030).....	16
Scorpion 490-4 S&P high pressure filter (ADGT1040R/1040L).....	17
Scorpion 490-4 S&P cooler (ADGT1510R/L).....	18
Scorpion 490-4 S&P return filter (ADGT1049).....	19
Scorpion 490-4 S&P cylinderblock rear-frontmount (ADGT1514R/1514L).....	20
Scorpion 490-4 S&P switch box (ADGT1029).....	21
Scorpion 490-4 S&P lightboard rearmount (ADGT1500R).....	22
Scorpion 490-4 S&P lightboard frontmount (ADGT1500F).....	23
Scorpion 490-4 S&P accumulator (ADGT1436).....	24
Scorpion 490-4 S&P topcover (ADGT1503R/ADGT1503L).....	25
Scorpion 490-4 S&P frontcover (ADGT1506R/ADGT1506L).....	26
Scorpion 490-4 P PVG valve with AHC (ADGT1537).....	27
Scorpion 490-4 P PVG valve (ADGT1574).....	28
Scorpion 490-4 S PVG valve (ADGT1573).....	29
Scorpion 490-4 S&P 2 oilflows (ADGT1547).....	30
Scorpion 490-4 P dobbelt contra valve auto flex (ADGT1308).....	31
Scorpion 490-4 S&P main hydraulic drive rearmount (ADGT1501).....	32
Scorpion 490-4 S&P main hydraulic drive frontmount (ADGT1501.1) NY.....	33
Scorpion 490-4 S&P valve HIC (ADGT1052) måske ny.....	35
Scorpion 490-4 P joystick and controlbox.....	37
Scorpion 490-4 S&P PTO.....	38
Scorpion 490-4 P switchboard and loom.....	39
Scorpion 490-4 S&P hydraulic hoses.....	39
Scorpion 490-4 S&P 4 pkt. stabilization upper – Option.....	40
Scorpion 490-4 P arm cpl.....	44
Scorpion 490-4 P outer arm (ADGT1512R/L).....	45
Scorpion 490-4 S&P inner arm (ADGT1511R/L).....	47
Scorpion 490-4 S&P lift arm (ADGT1033R/1033L) måske ny.....	49
Scorpion 490-4 P rotor flex (ADGT1257/1257.1).....	50
Scorpion 490-4 P rotor (ADGT1258).....	52
Scorpion 490-4 S&P slewcyylinder (cylinder 1) NY skal der ikke nipler i ??.....	53
Scorpion 490-4 S&P liftcylinder (cylinder 2).....	54
Scorpion 490-4 S&P cylinder (cylinder 3).....	55
Scorpion 490-4 S&P dippern cylinder (cylinder 4).....	56
Scorpion 490-4 P headcylinder (cylinder 5).....	57
Stickers.....	58

Introduction

Dear customer!

Your new GreenTec machine is constructed with background in more than 20 years' experience with tractor-mounted machines to maintenance of green areas. This machine is produced by the latest technology and recognized safety regulations, standards and regulations.

We want to make a product available in such a way, that neither the use of the machine during transportation or maintenance of the machine causes any damage or misunderstandings.

This parts list contains information that are important and useful for maintaining your GreenTec machine's reliability, dependability and value.

You are welcome to visit our website www.greentec.eu - where the login via the dealer's access gives you the latest updates on instructional and part books on our entire product range.

We hope you will be pleased with your new GreenTec machine.

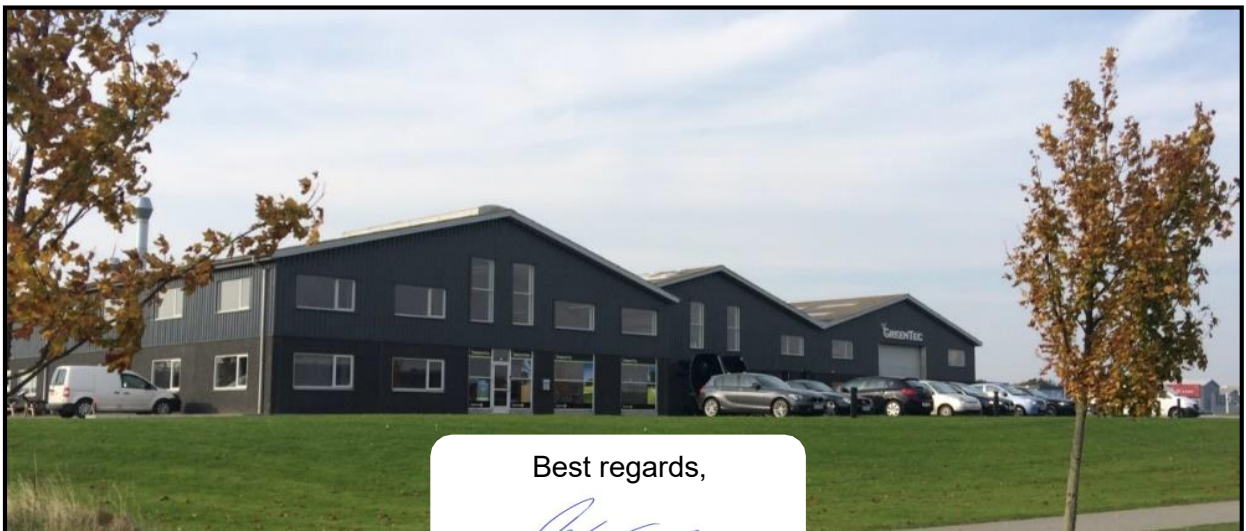

Best regards,



John Christensen
Sales Director GreenTec A/S

GreenTec's vision is to develop and sell quality machines for the maintenance of green areas, including in agriculture, in industry, at airports and in the local sector. Through innovative product development, we will strive to become a leader in our field.

All machines are developed in a simple and functional design in close cooperation with dealers and end users. It is our goal to cover every need in the market segment with preferably two different solutions. In-depth analysis of requirements and serious advice to the customer is offered the best solution, where individual needs can be met through the modularity of the product program.

Our goal is also to offer the best possible after sales service, and a quick and efficient spare parts supply.

Useful information

Before using the machine for the first time, it's the seller's responsibility that the buyer is given this parts list. If the machine is resold, the parts list must be transferred to the new owner.

Please fill out the list below to ensure that the necessary information is at hand when ordering spare parts et c.

Serial No

Delivery date

Dealer

Tel. / E-mail



Merkurvej 25
DK 6000 Kolding
Denmark
Tel: +45 75553644
E-mail: info@greentec.eu
web: www.greentec.eu
Opening hours: Mon-Fri 8-16

Ordering parts

When ordering parts please refer to your parts list to help your dealer with your order.

- **Part number and quantity**
- **Description**
- **Machine model number**
- **Serial number of the machine**
- **Delivery instructions (e.g. next day).**

Delivery is normally via carrier direct to your dealer. Please check with your dealer for stock availability and arrangement of dispatch. Ensure you or your dealer has sufficient cover for parts requirement outside factory hours.

Important Note:

The information contained in this manual is correct at the time of publication. However, in the course of constant development, changes in specification are inevitable. Should you find the information given in this book different to the machine it relates to, please contact the “After Sales Department” for advice.

Key:

LH: Left hand
RH: Right hand

Spare Part
Scorpion 490-4 S&P cpl. Right/Left

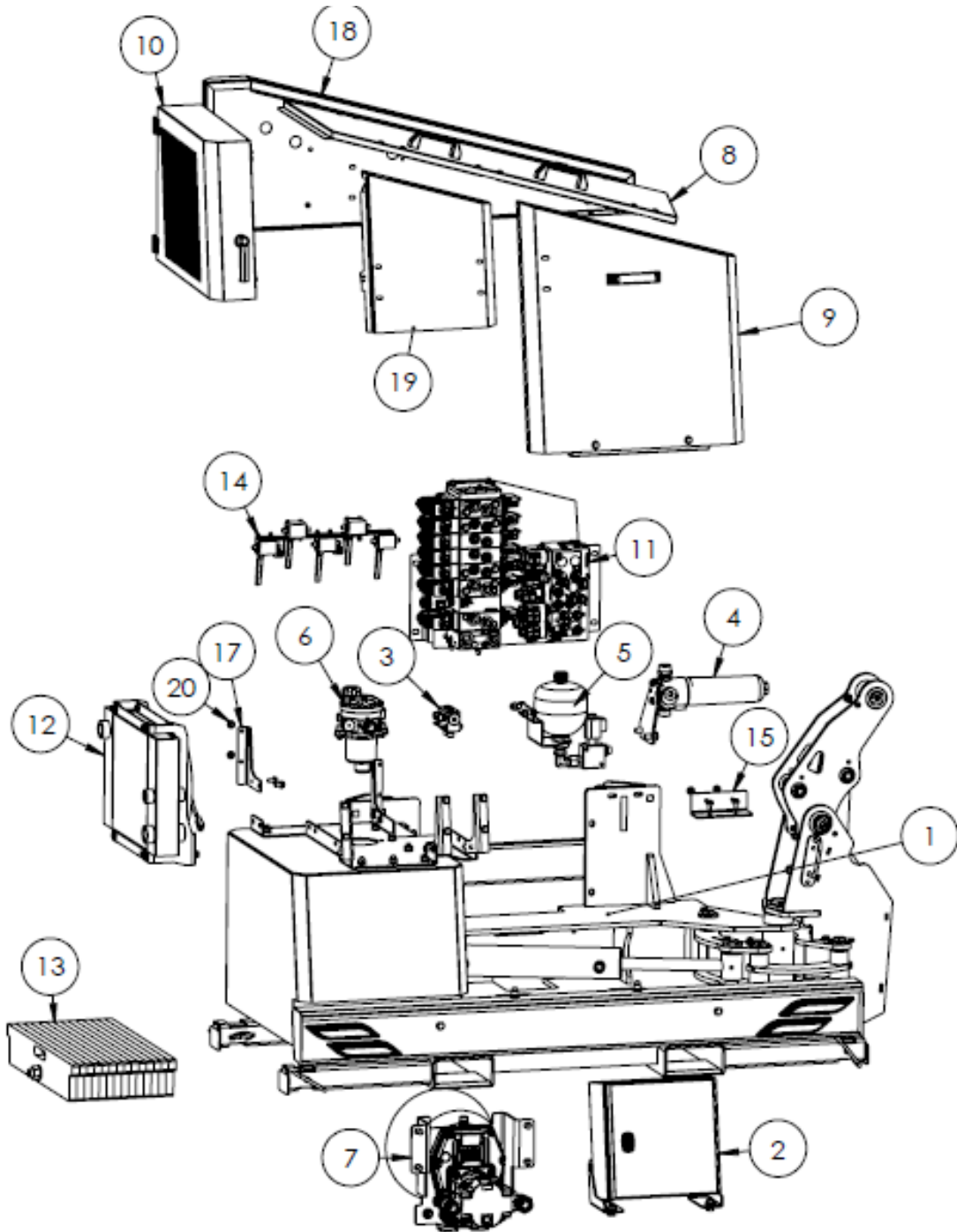

ITEM NO.	PART NUMBER	DESCRIPTION	Qty
1	6703300R/L	Mainframe cpl.	1
2	1029	Main switch box "see assembly drawing"	1
3	1039	Splitterblock "see assembly drawing"	1
4	1040	High pressure filter "see assembly drawing"	1
5	1048	Accumulator "see assembly drawing"	1
6	1049	Return filter "see assembly drawing"	1
7	1501	Main hydraulic drive "see assembly drawing"	1
8	1503	Topcover "see assembly drawing"	1
9	1506	Frontcover "see assembly drawing"	1
10	1507	Cover "see assembly drawing"	1
11	1509	Plate f/valves "see assembly drawing"	1
12	1510	Cooler "see assembly drawing"	1
13		Counterweight "see assembly drawing"	1
14	1514	Cylinderblocking "see assembly drawing"	1
15	6703322	Bracket f/cover	1
16	6703315R/L	Holder	3/2
18	6703309R/L	Backplate	1
19	6703310R	Frontcover f/tank	1
20	6703730	Flangebolt	24

Scorpion 490-4 S&P main frame R/L (ADGT1505R/ADGT1505L)

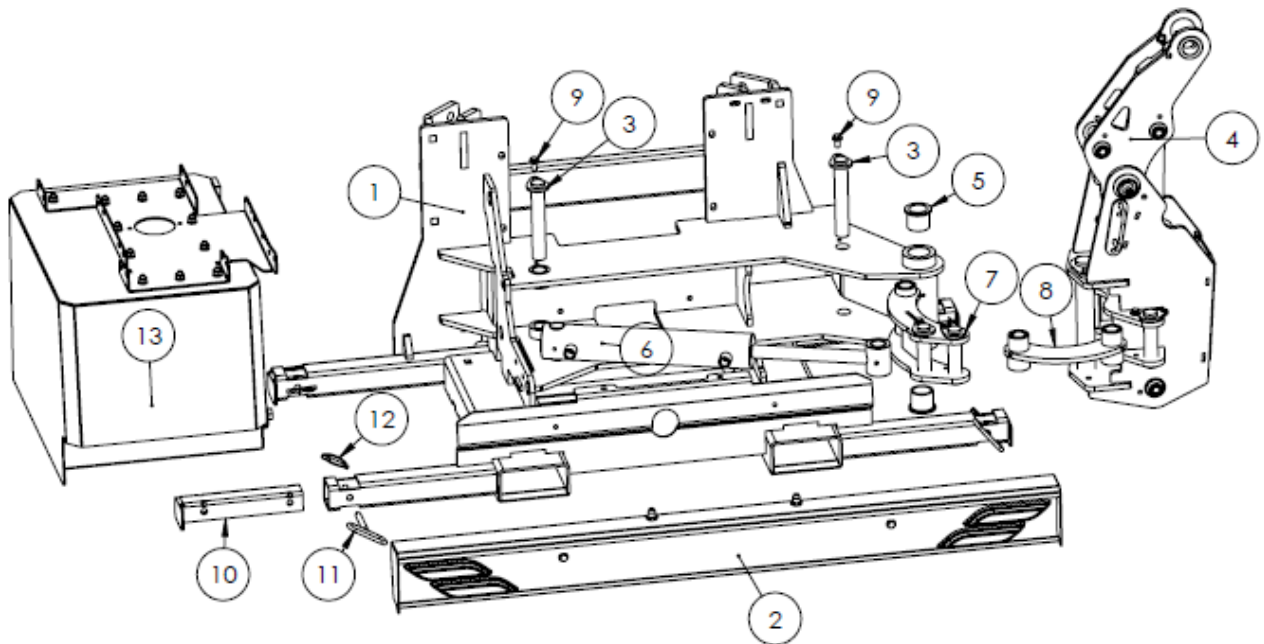

ITEM NO.	PART NUMBER	DESCRIPTION	Qty
1	6703300R/L	Mainframe cpl.	1
2		Main switch box "see assembly drawing"	1
2	1500	Lightboard cpl. "see assembly drawing"	1
3	6703320	Pear pin	2
4	1504	Tower R/L "see assembly drawing"	1
5	9020062	Bronze bushing	2
6	6703342	Cylinder nr. 1	1
7	1515	Swivel arm "see assembly drawing"	1
8	1516	Lift arm "see assembly drawing"	1
9	6702626	Flangebolt	2
10	9020070	Legs	4
11	9040072	Special pin	4
12		Split	4
13	1508	Tank cpl.	1

Scorpion 490-4 S&P tower R/L (ADGT1504R/ADGT1504L)

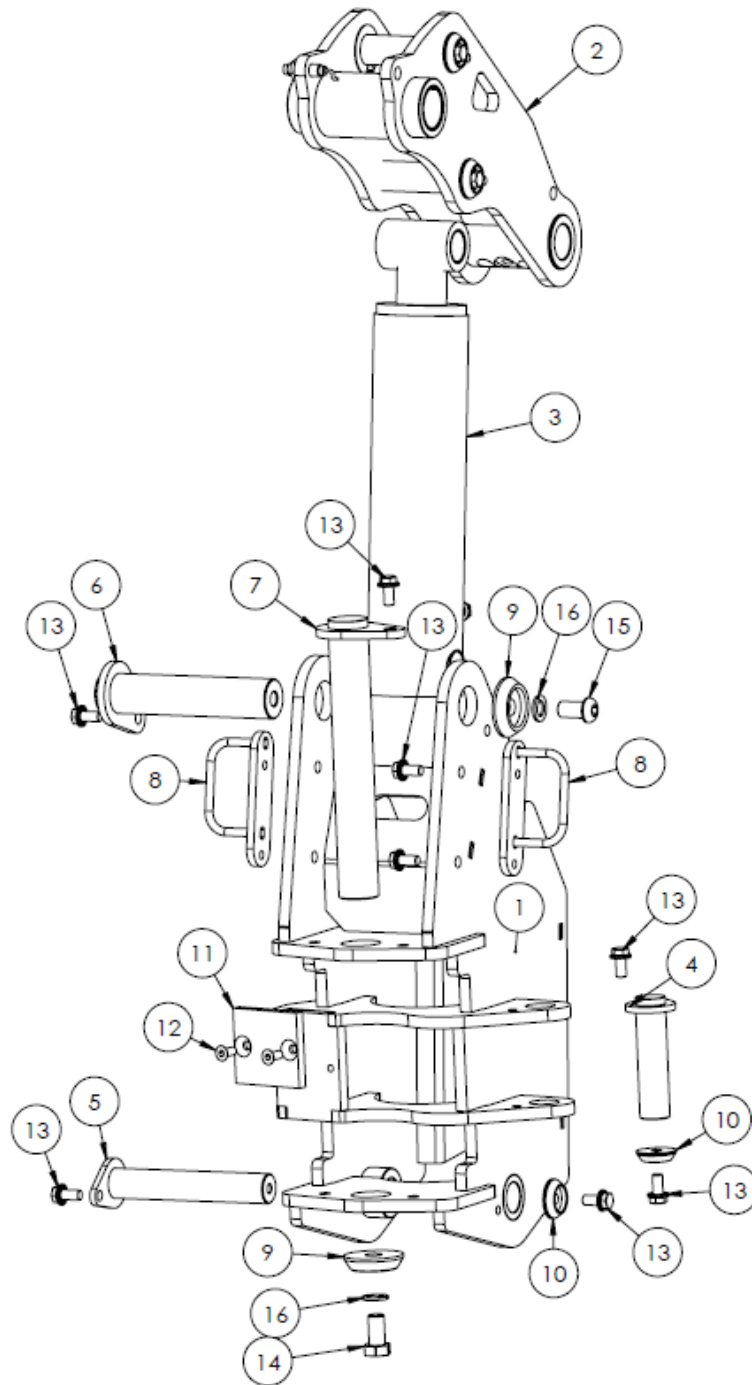

ITEM NO.	PART NUMBER	DESCRIPTION	QTY.
1	6703303R/L	Tower Right/Left	1
2	1033	Liftarm "see assambly drawing"	1
3	6703301	Cylinder "see assambly drawing"	1

4	9020026	Pear pin	1
4a	6702064	Expander bolt	1
5	6703320	Pear pin	1
6	9020067	Pear pin	1
6a	6703265	Expander bolt	1
7	9020066	Pear pin	1
7a	6702074	Expander bolt	1
8	6703343	Hoseholder	1
9	9020010	Stopwasher	2
10	9020011	Stopwasher	2
11	0168001.0	Spacer	1
12	9040180	Bolt	2
13	6702626	Bolt	10
14	6702119	Bolt	1
15	6701971	Bolt	1
16	8222013	Washer	2
18	9020115	Hose holder	1
18a	6702695	Hose holder, special for expander bolt	1
19	8222002	Bolt	1
20	6702011	Bolt	1

Scorpion 490-4 S&P hose for greasing (ADGT1198) måske ny

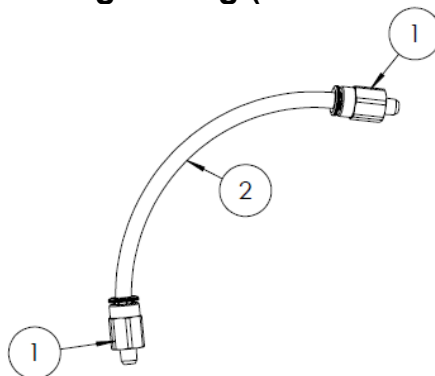

ITEM NO.	PART NUMBER	DESCRIPTION	QTY.
1	9040165	Nipple	2
2	6701817	Hose for greasing	1

Scorpion 490-4 S&P lift arm (ADGT1516)

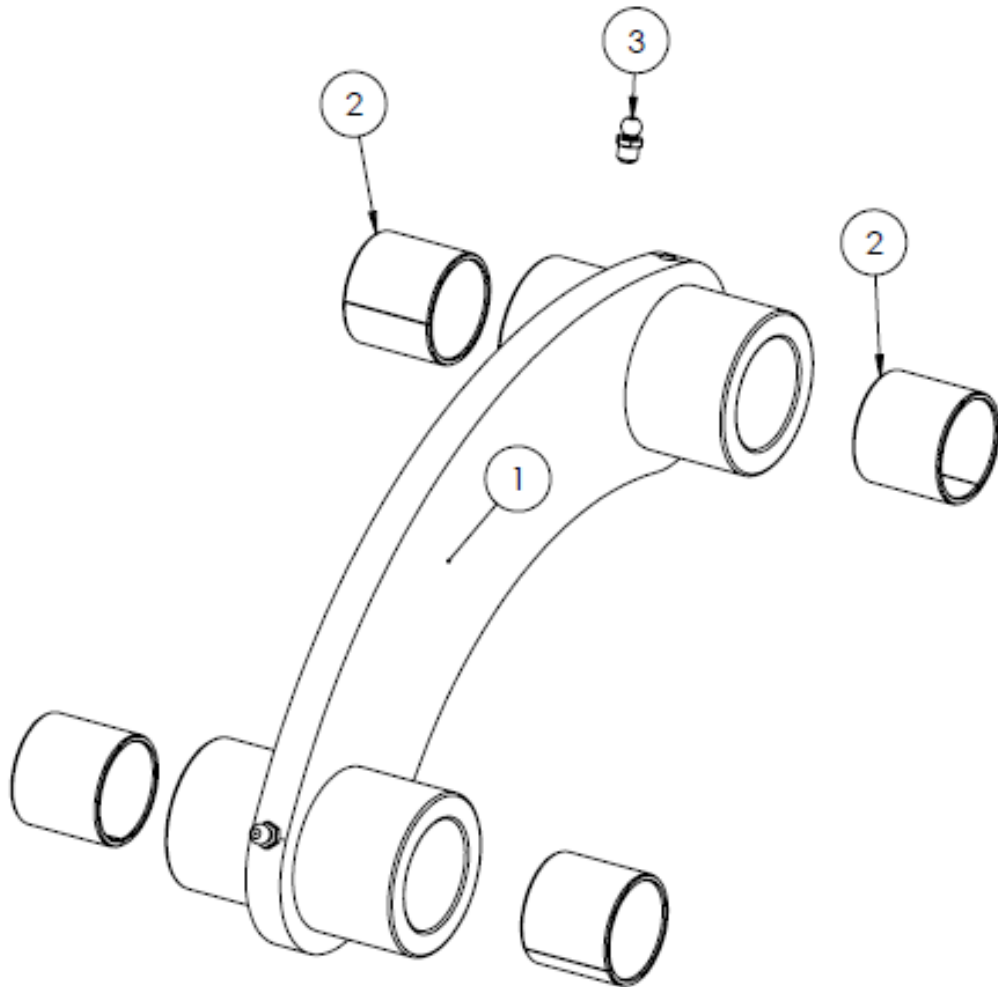

ITEM NO.	PART NUMBER	DESCRIPTION	QTY.
1	6703341	Lift arm	1
2	9020029	Bronzebushing	4
3	8222027	Greasnipple	2

Scorpion 490-4 S&P swivel arm (ADGT1515R/1515L)

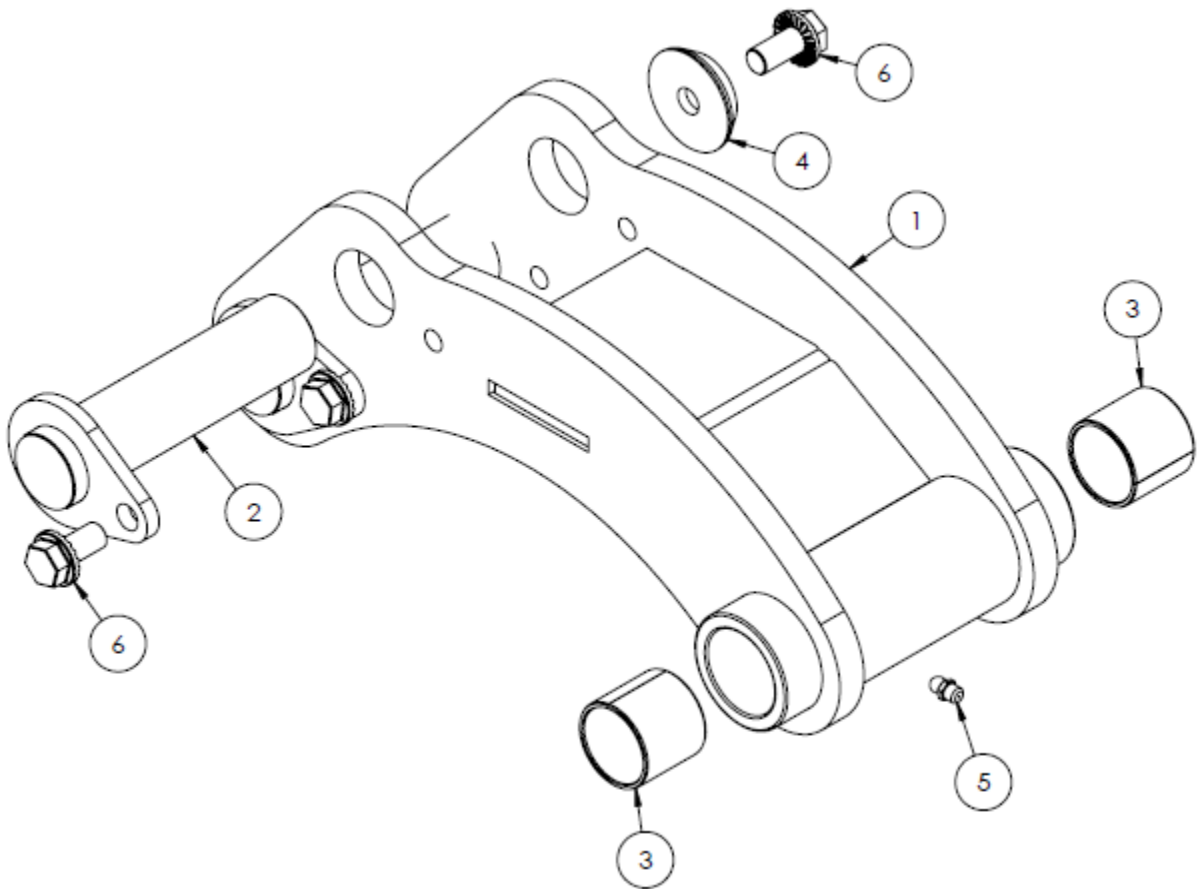

ITEM NO.	PART NUMBER	DESCRIPTION	QTY.
1	6703340	Swivel arm Right	1
2	9020026	Pear pin	2
NS	6702064	Expander bolt	
3	9020029	Bronzebushing	2
4	9020011	Stopwasher	2
5	8222007	Greasnipple	1
6	6702626	Flangebolt	4

Scorpion 490-4 S&P counterweight (ADGT1513)

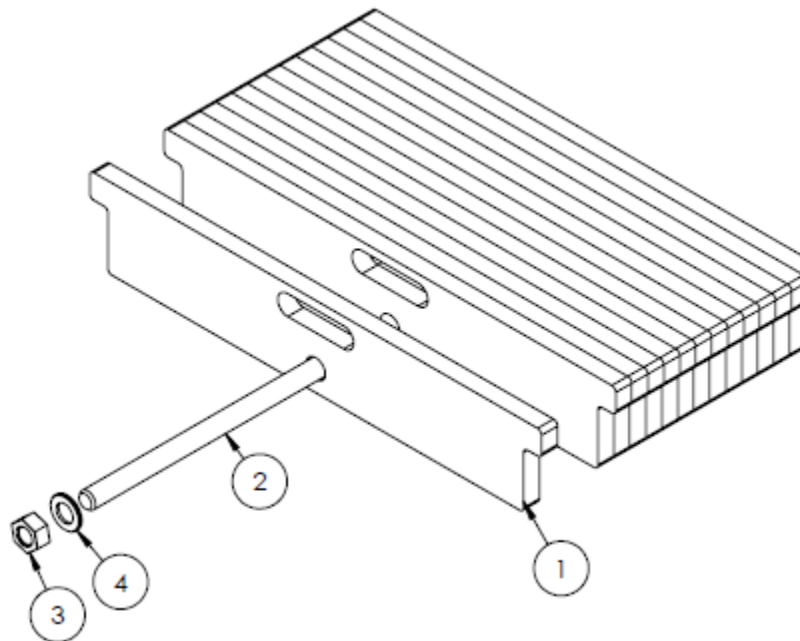

ITEM NO.	PART NUMBER	DESCRIPTION	QTY.
1	9020069	Counterweight	14
2	6703324	M20 Rod	1
3	9040182	Lock nut	1
5	9040183	Washer	1

Scorpion 490-4 S&P cpl. tank (ADGT1508R/L)

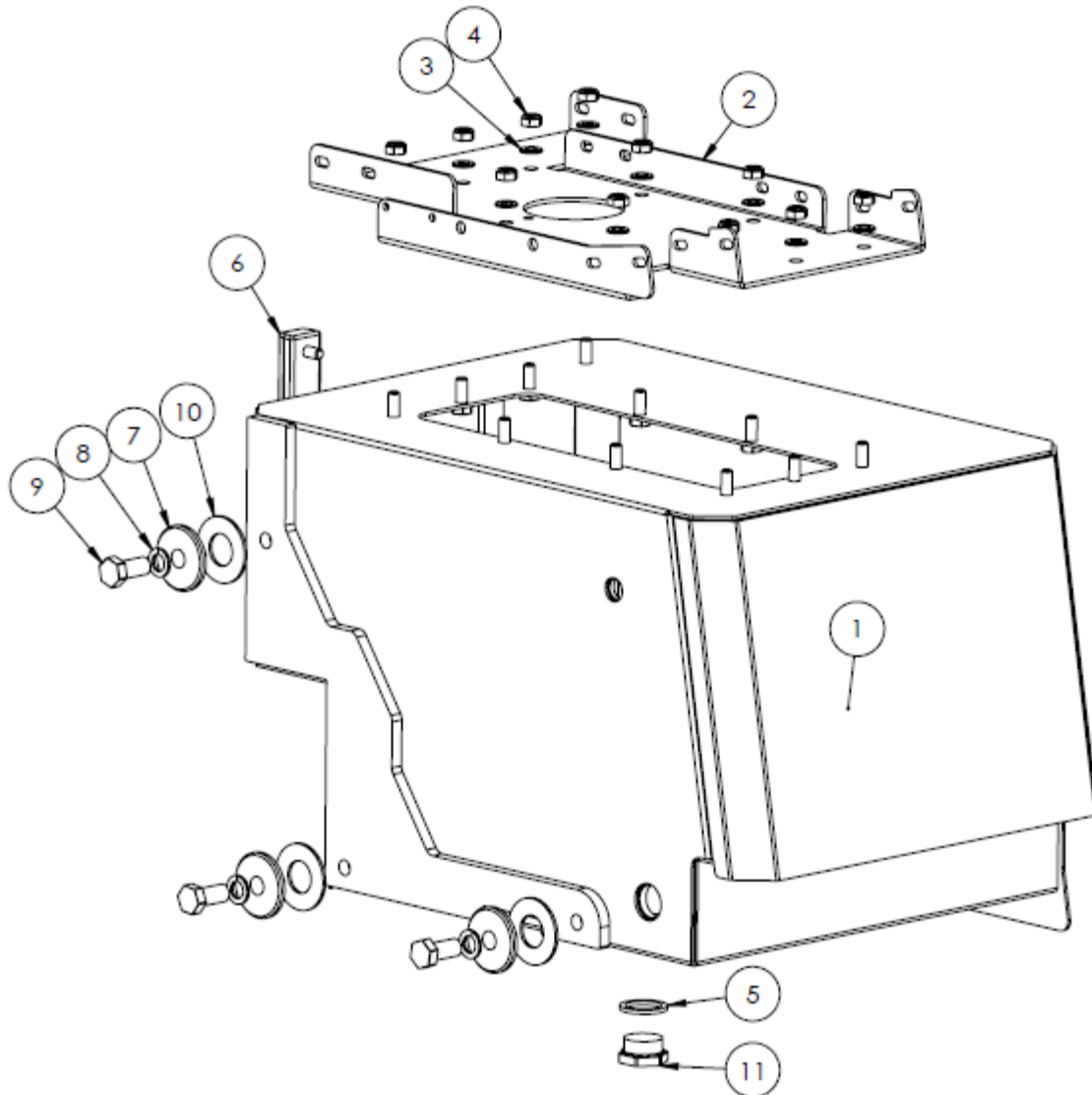

ITEM NO.	PART NUMBER	DESCRIPTION	QTY.
1	6703302R/6703302L	Tank R/L	1
2	6703314R/6703314L	Tankcover top R/L	1
3	8222024	Washer	11
4	8222023	Locknut	11
5	8290034	Bonded seals	1
6	9020114	Oil gauge	1
7	6703307	Washer	3
8	8222013	Washer	3
9	8222012	Bolt	3
10	6703308	Rubberwasher	3
11	6701999	Plug	1

Scorpion 490-4 S&P splitterblock rear-frontmount (ADGT1030)

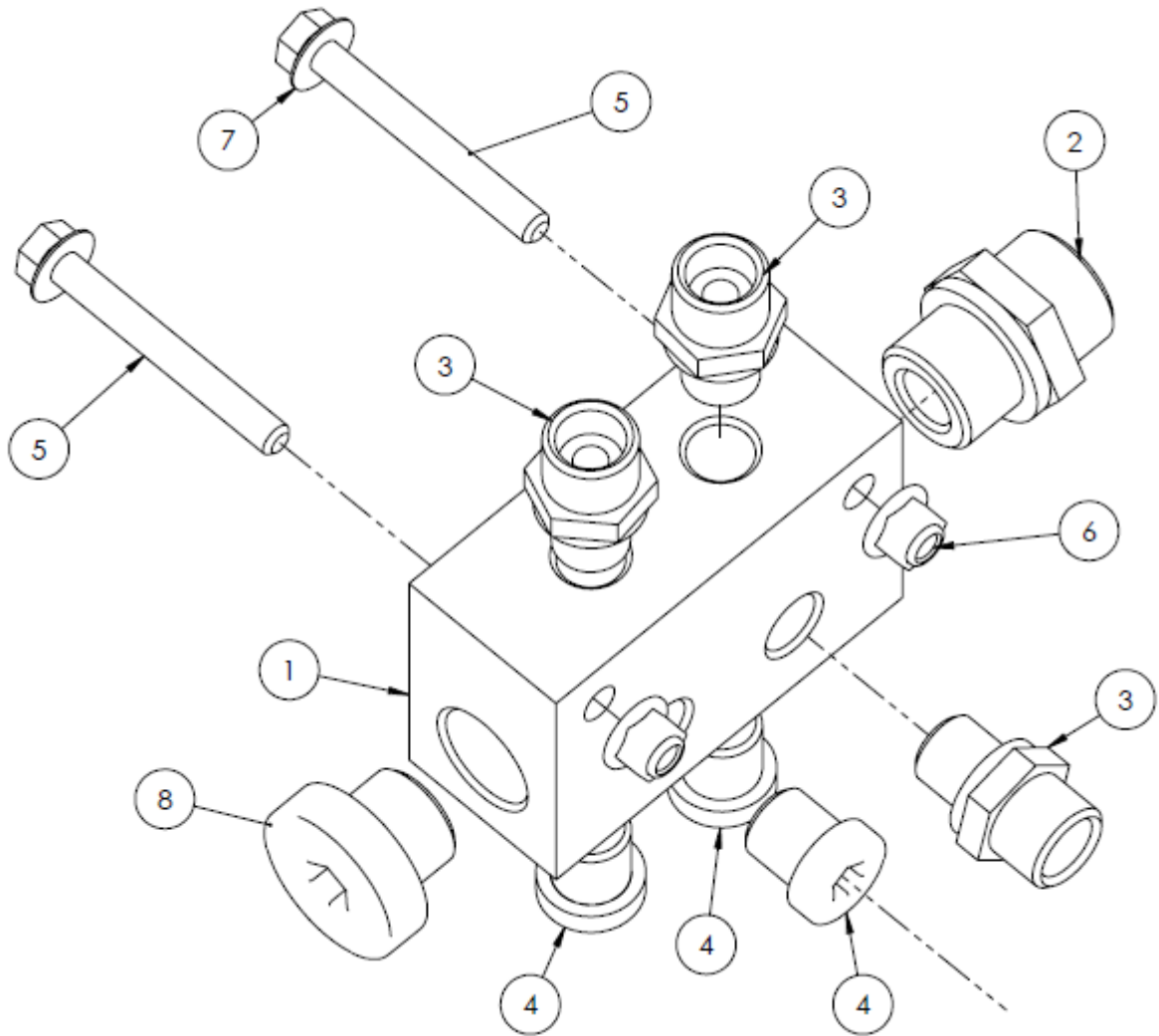

ITEM NO.	PART NUMBER	DESCRIPTION	QTY.
1	9040100	Splitterblock	1
2	9040116	Nipple	1
3	9040118	Nipple	3
4	81823025	Plug	3
5	8752003	Bolt	2
6	9040187	Flangenut	2
7	8482004	Washer	2
8	9020305	Plug	1

Scorpion 490-4 S&P high pressure filter (ADGT1040R/1040L)

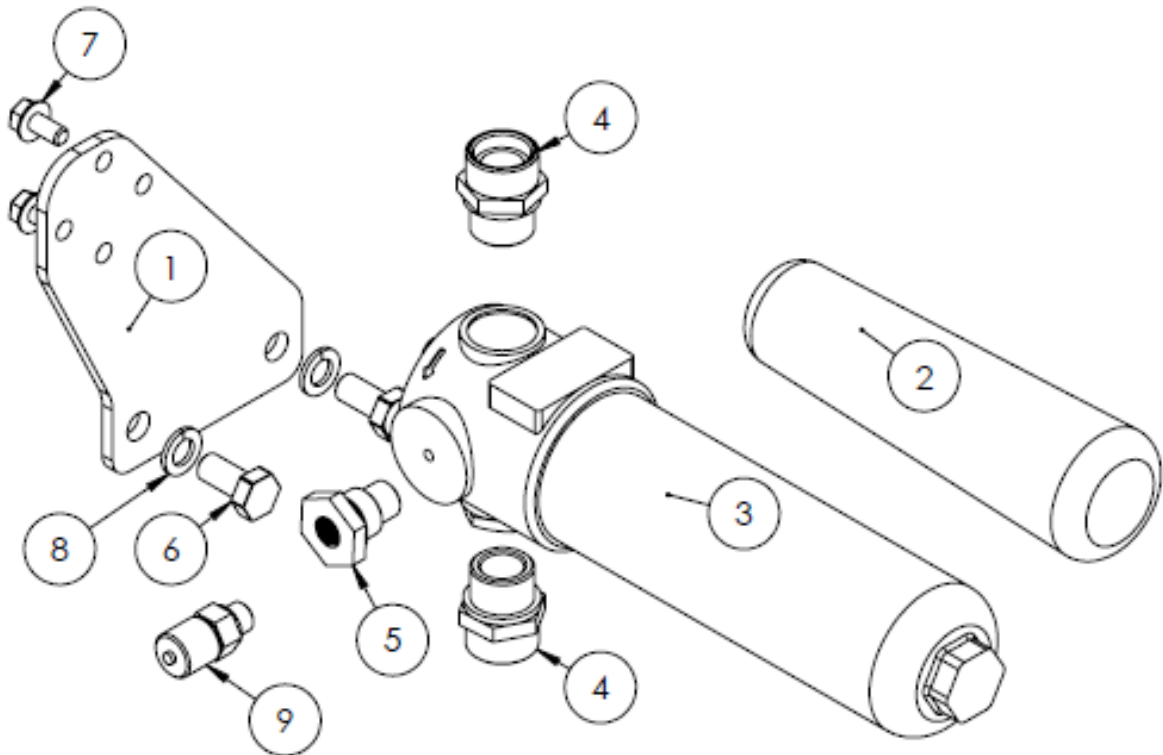

ITEM NO.	PART NUMBER	DESCRIPTION	QTY.
1	9020044	Holder for highpressure filter	1
2	9040075	Filter replacement	1
3	9020084	High pressure filter	1
4	9020111	Nipple	2
5	9040130	Plug	1
6	9040239	Bolt	2
7	8142011	Bolt	2
8	8222005	Washer	2
9	6703007	Minimesh	1
NS	6701610	Sealkit cpl.	1
NS	EFTE300	Filterkit cpl. (press + return)	

Scorpion 490-4 S&P cooler (ADGT1510R/L)

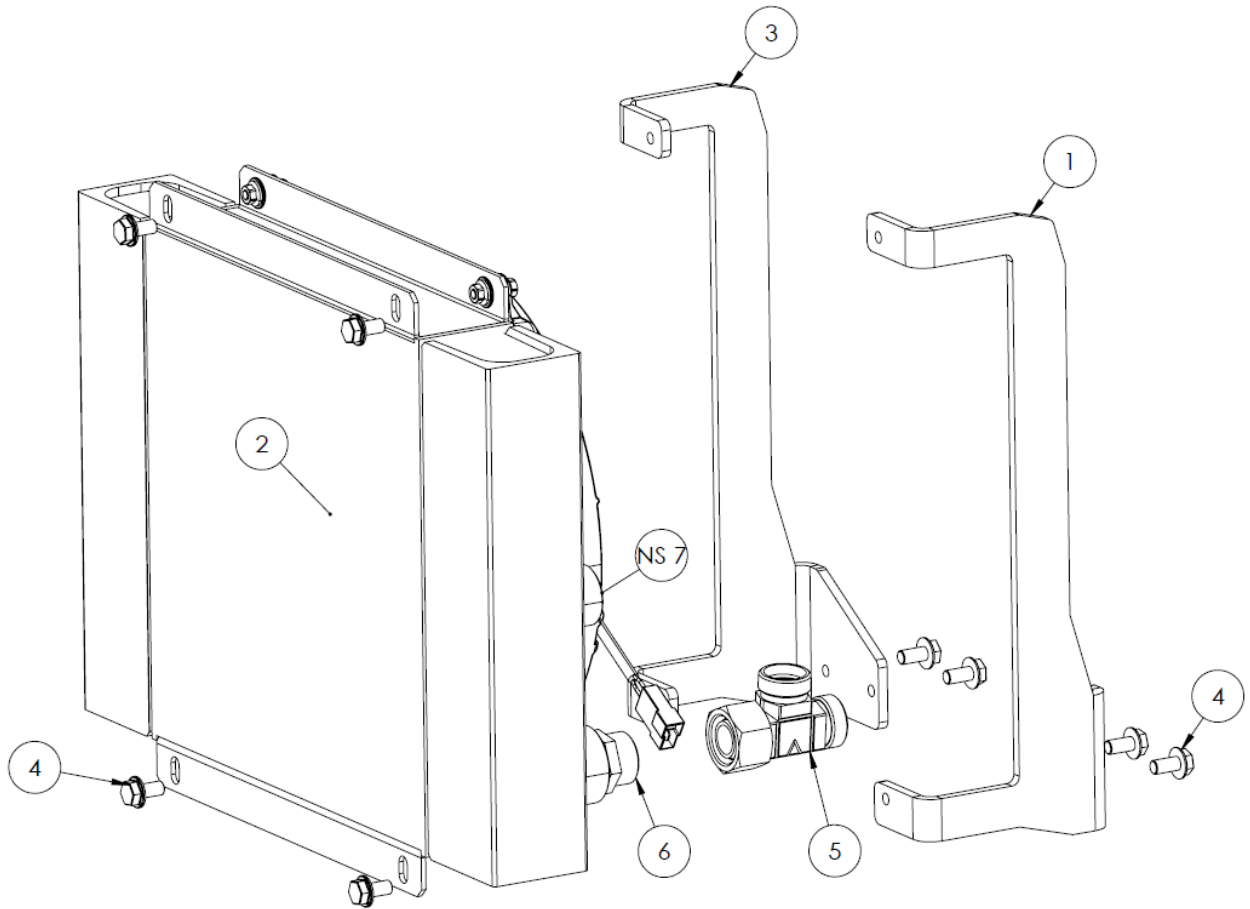

M NO.	PART NUMBER	DESCRIPTION	QTY.
1	9020046	Cooler	1
1	6703329R	Bracket for cooler Right	1
2	6703385	Cooler	1
3	6703329L	Bracket for cooler Left	1
4	6702594	Bolt	8
5	9020306	Nipple	1
6	1784712000	Nippel	2
7 NS	9040252	Thermostat	1
NS	9020046.1	Blower f/cooler	
NS	6703434	Plug	1
NS	6703435	Plug	2

Scorpion 490-4 S&P return filter (ADGT1535)

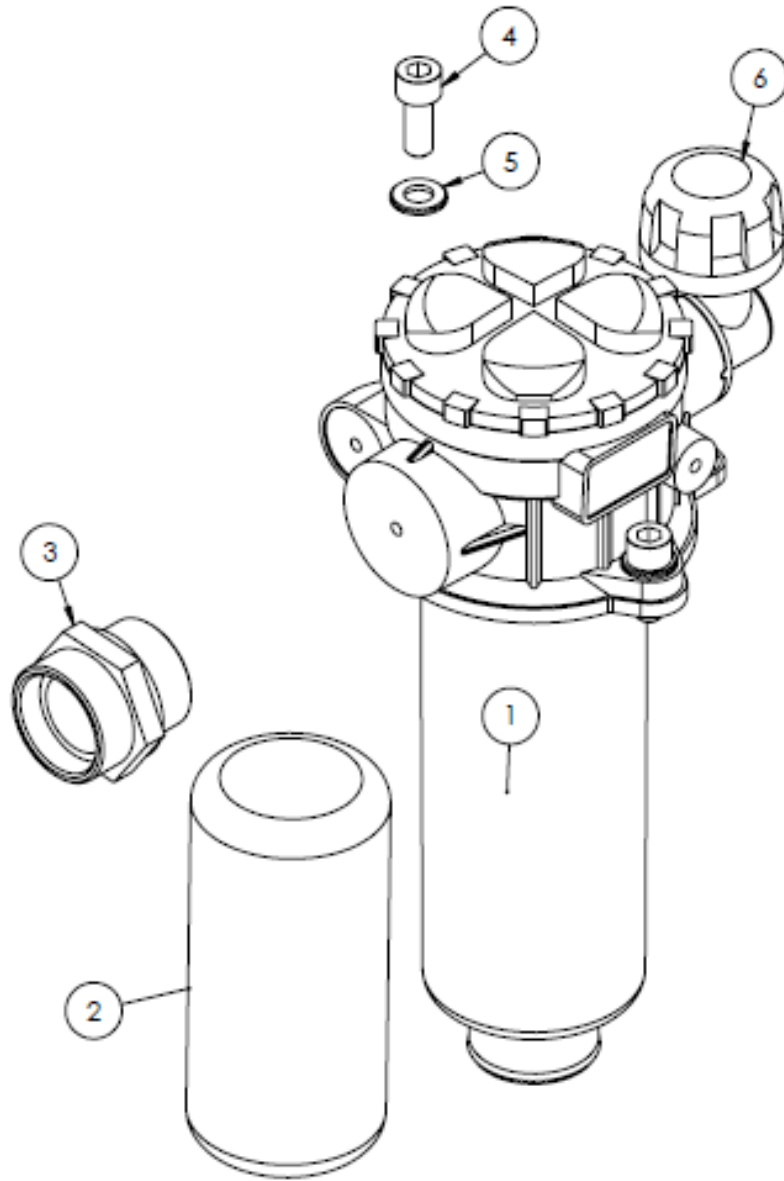

ITEM NO.	PART NUMBER	DESCRIPTION	QTY.
1	9040059	Returnfilter	1
2	9040074	Filter replacement	1
3	9040114	Nipple	1
4	8022001	Bolt	2
5	8222003	Washer	2
6	6701639	Breather filter	1
NS	6701580	Sealkit cpl.	1

Scorpion 490-4 S&P cylinderblock rear-frontmount (ADGT1514R/1514L)

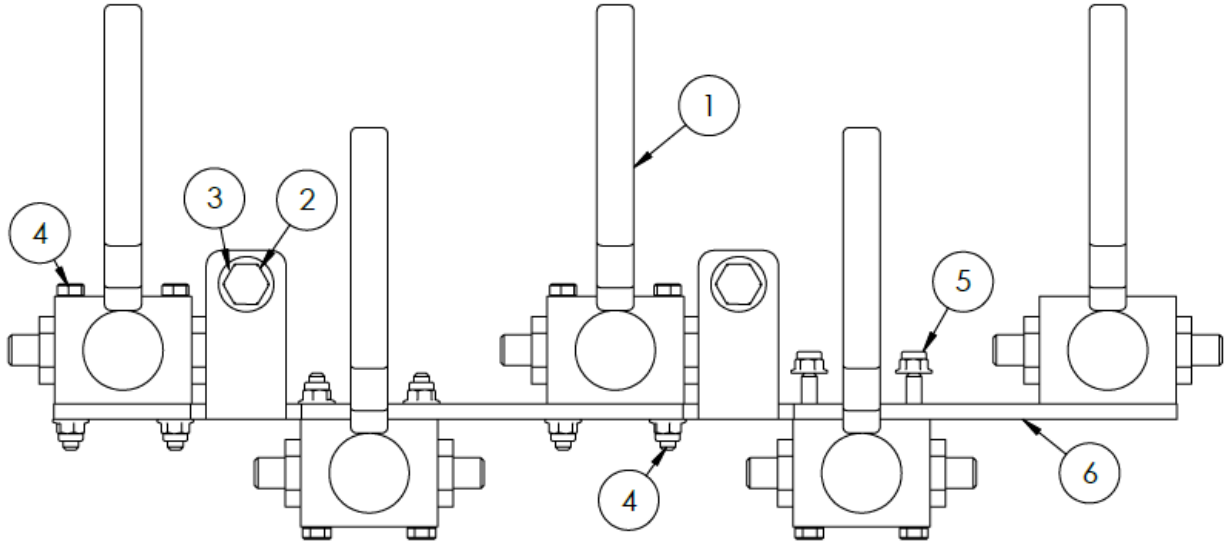

ITEM NO.	PART NUMBER	DESCRIPTION	QTY.
1	9040098	Ball velve 10L	5
2	6702915	Flangebolt	2
3	9040190	Lock nut	2
4	9040188	Bolt	8
5	6701569	Nut	8
6	6703335R/L	Bracket for ball valve Right/Front	1

Scorpion 490-4 S&P switch box (ADGT1545)

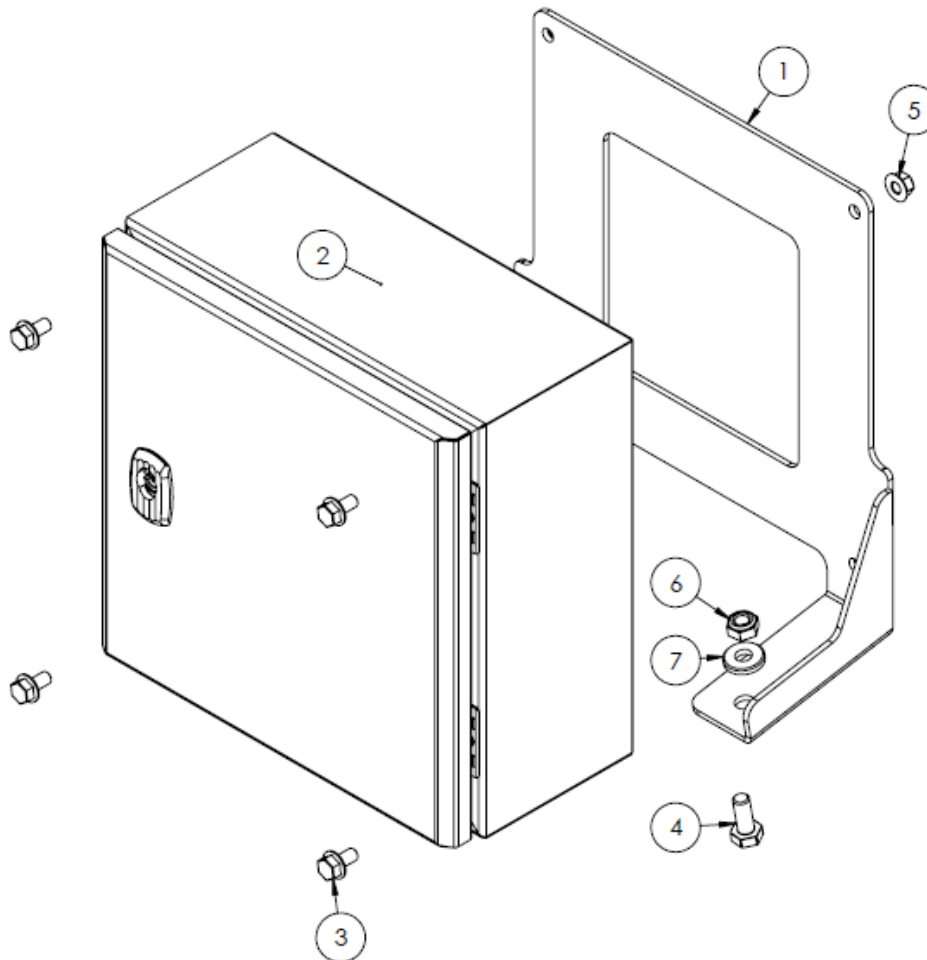

ITEM NO.	PART NUMBER	DESCRIPTION	QTY.
1	9020031	Plate for electric box	1
2	6703528/9040085	Switch box house	1
3	8142011	Bolt	4
4	8222006	Bolt	2
5	9040190	Flangenut	4
6	6701984	Flangenut	2
7	6701641	Washer	2
NS	9040220	Handle	1

Scorpion 490-4 S&P lightboard rearmount (ADGT1540R)

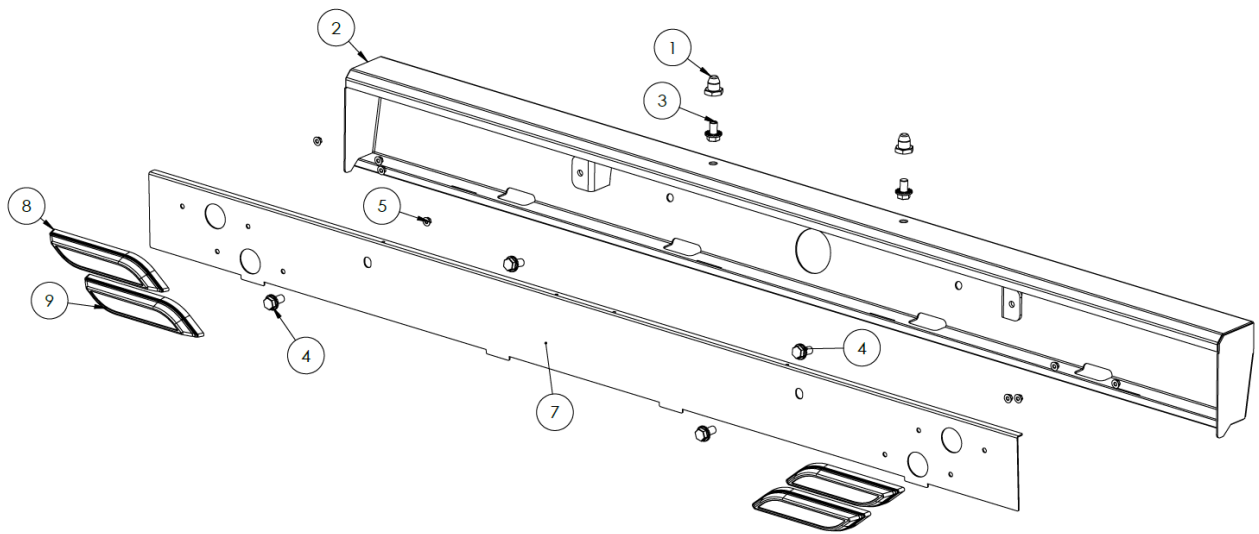

ITEM NO.	PART NUMBER	DESCRIPTION	QTY.
1	9040056	Guide pin	2
2	6703304	Lightboard	1
3	6702616	Bolt	2
4	8222035	Bolt	4
5	9040186	Nut	6
7	6703336	Light mountplate	1
8	9020103	Light back Left	1
9	9020102	Light back Right	1
NS	9040201	Loom f/light	1

Scorpion 490-4 S&P lightboard frontmount (ADGT1500F)

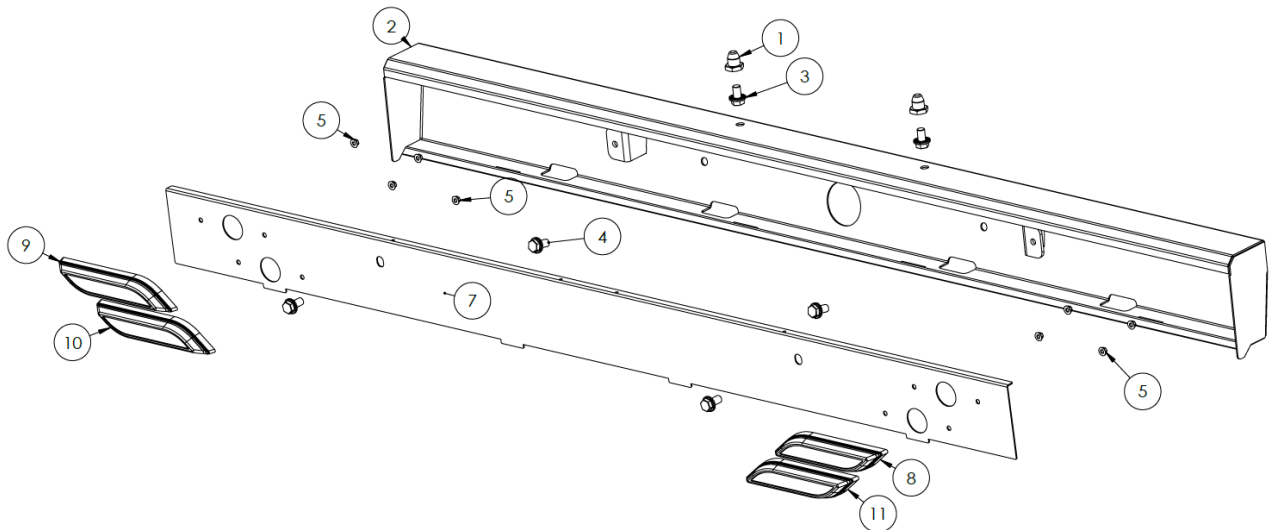

ITEM NO.	PART NUMBER	DESCRIPTION	QTY.
1	9040056	Guide pin	2
2	6703304	Lightboard	1
3	6702616	Flangebolt	2
4	6702626	Flangebolt	4
5	9040186	Flangenut	8
7	6703306	Light mountplate	1
8	9020105	Light back (Turn signal)	1
9	9020107	Light back (Turn signal)	1
10	9020108	Light back (Light Right)	1
11	9020109	Light back (Light Left)	1
NS	9040199	Loom f/light	1

Scorpion 490-4 S&P accumulator (ADGT1436)

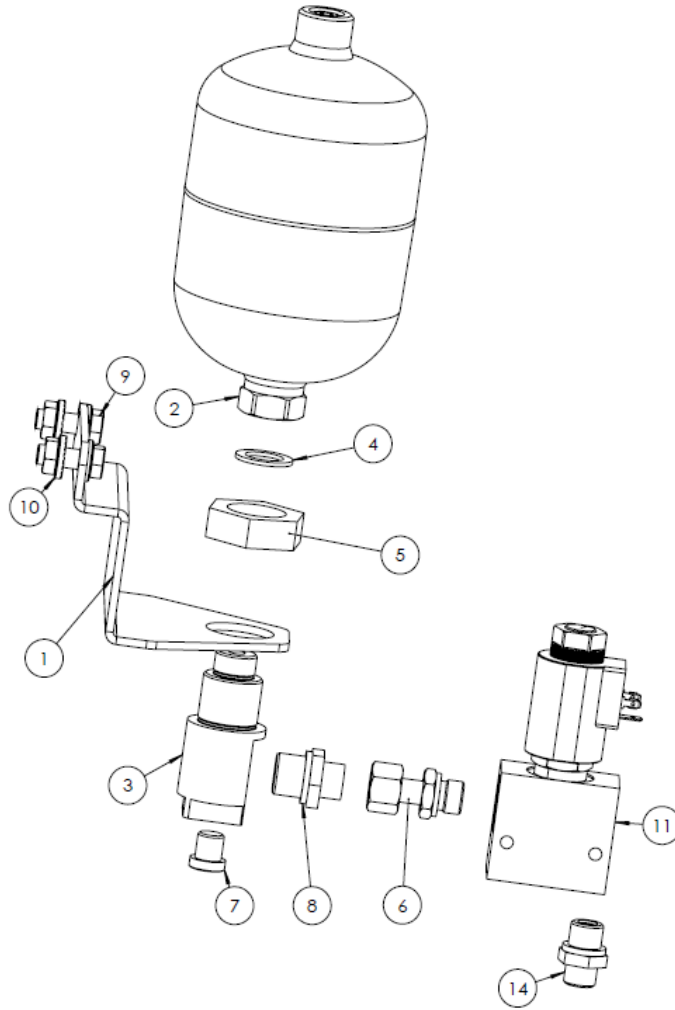

ITEM NO.	PART NUMBER	DESCRIPTION	QTY.
1	9020117	Bracket	1
2	6703164	Accumulator 1L	1
3	6703200	Nipple	1
4	6703010	Seals	2
5	6703201	Nut	1
6	6702020	Nipple	1
7	81823025	Plug	1
8	9040119	Nipple	1
9	6702694	Bolt	2
10	6702398	Nut	2
11	6703267	Valvehouse	1
14	9040120	Nipple	1

Scorpion 490-4 S&P topcover (ADGT1503R/ADGT1503L)

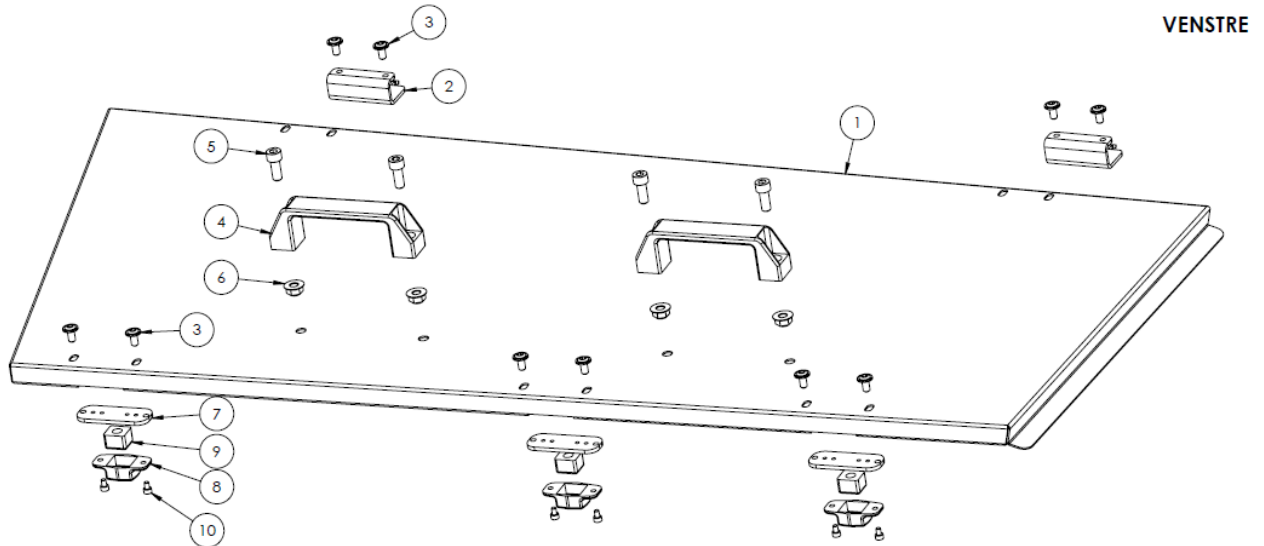

ITEM NO.	PART NUMBER	DESCRIPTION	QTY.
1	6703312R/6703312L	Cover R/L	1
2	6703316	Bracket	2
2	9040091	Rubberstop	2
3	6703323	Bolt	10
4	8777513	Plast hinge	2
5	8142014	Bolt	4
6	9040190	Lock nut	4
7	6703337	Adapter f/doorholder	3
8	6703318	Doorholder	3
9	6703319	Doorholder	3
10	6703326	Bolt	6

Scorpion 490-4 S&P frontcover (ADGT1506R/ADGT1506L)

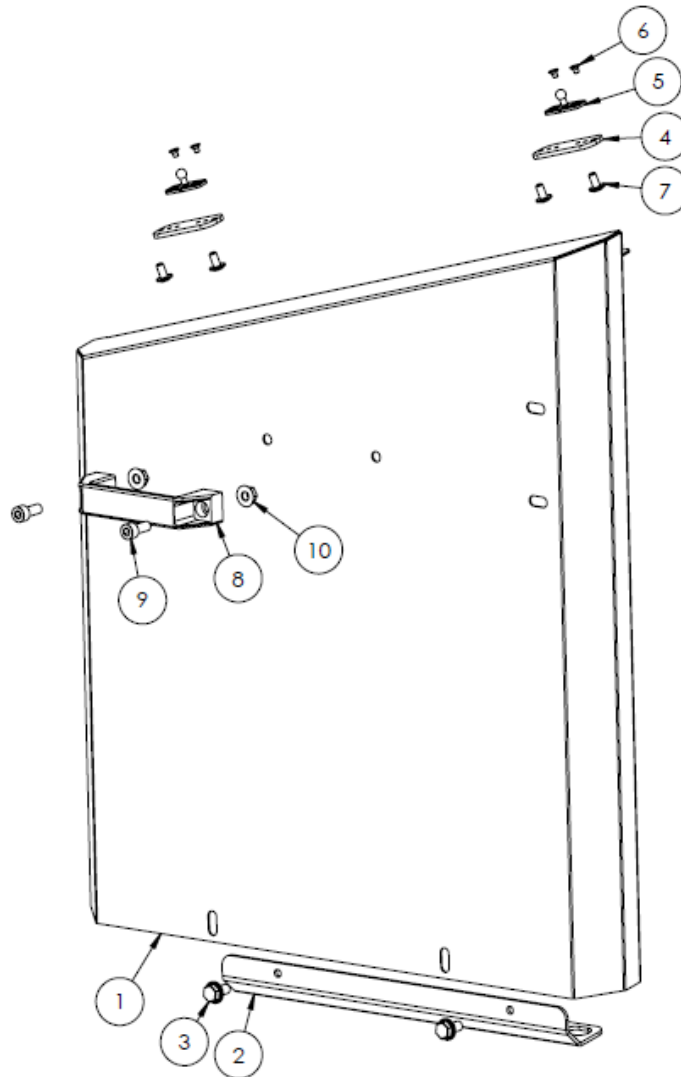

ITEM NO.	PART NUMBER	DESCRIPTION	QTY.
1	6703311R/6703311L	Frontcover R/L	1
2	6703321	Bracket	1
3	6703730	Bolt	2
4	6703337	Adapter f/doorholder	2
5	6703317	Doorholder	2
6	6703325	Bolt	4
7	6703323	Bolt	4
8	8777513	Plast hinge	1
9	8142014	Bolt	2
10	9040190	Lock nut	2

Scorpion 490-4 P PVG valve with AHC (ADGT1537)

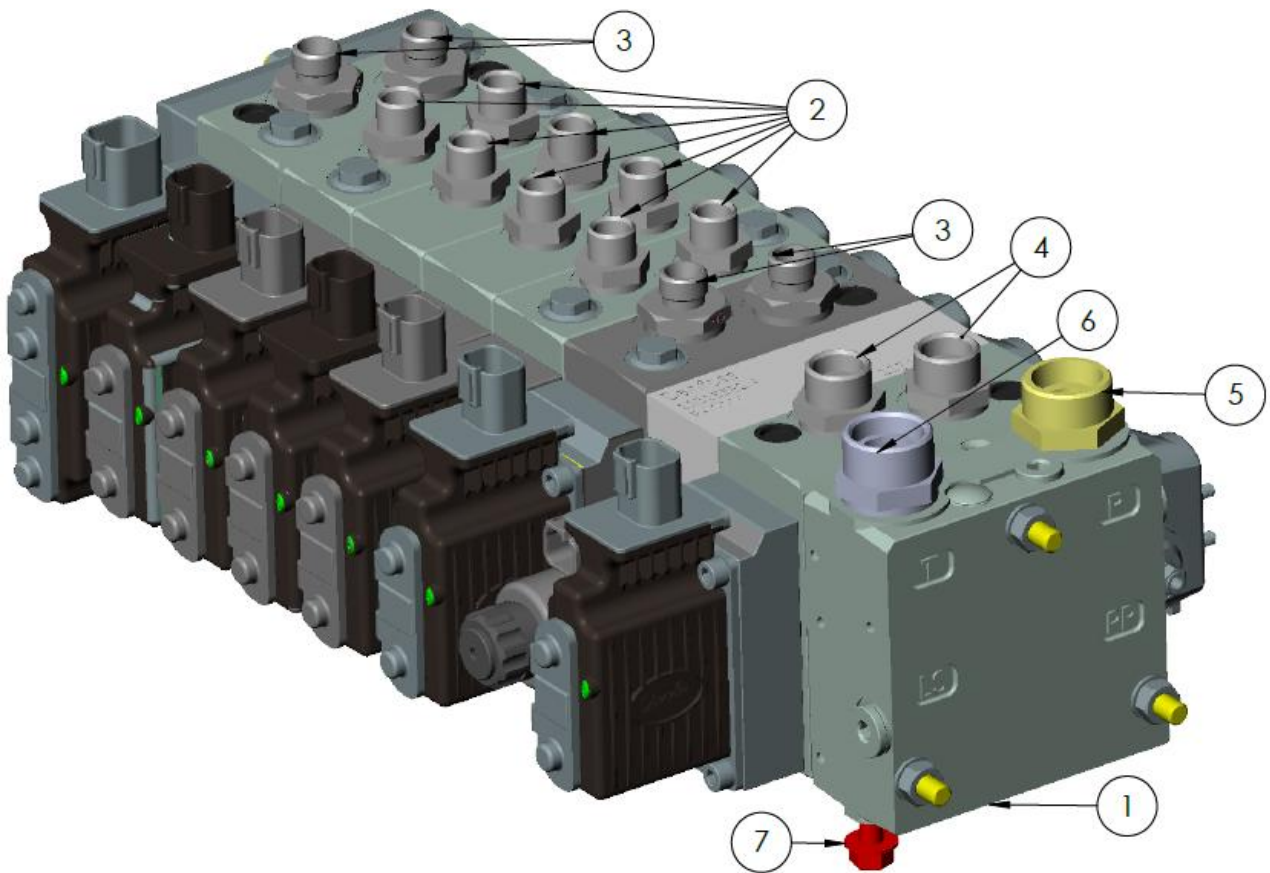

ITEM NO.	PART NUMBER	DESCRIPTION	QTY.
1	6703527	Valve PVG	1
2	9040120	Nipple	8
3	9020307	Nipple	4
4	9040116	Nipple	2
5	9020308	Nipple	1
6	9040211	Nipple	1
7	6702001	Bolt	4

Scorpion 490-4 P PVG valve (ADGT1574)

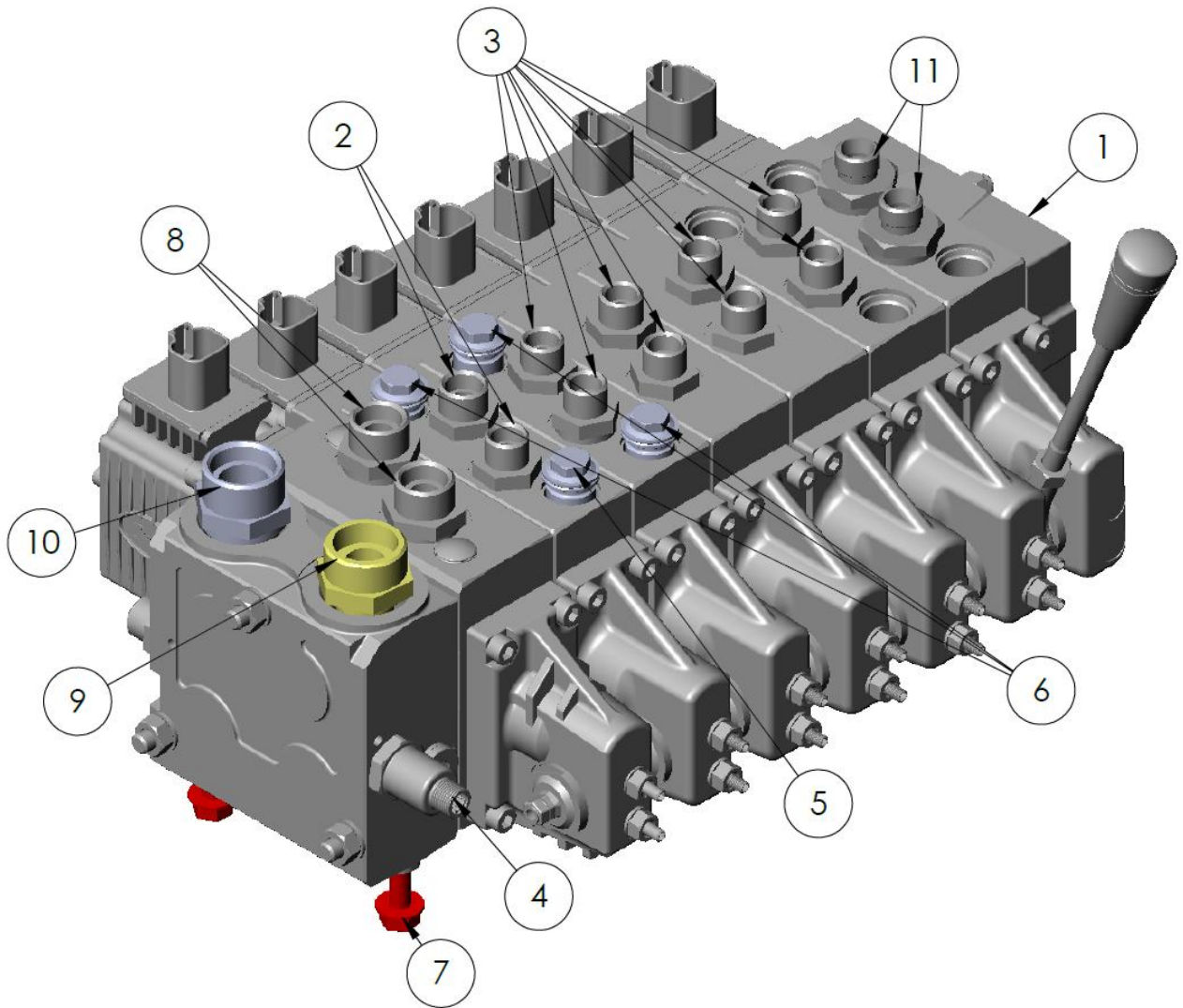

ITEM NO.	PART NUMBER	DESCRIPTION	QTY.
1	6703530	Valve PVG	1
2	9040117	Nipple	2
3	9040120	Nipple	8
5	9040208	Ventil	1
6	9040210	Ventil	3
7	8142011	Bolt	4
8	9040116	Nipple	2
9	9020308	Nipple	1
10	9020111	Nipple	1
11	9020307	Nipple	2

Scorpion 490-4 S PVG valve (ADGT1573)

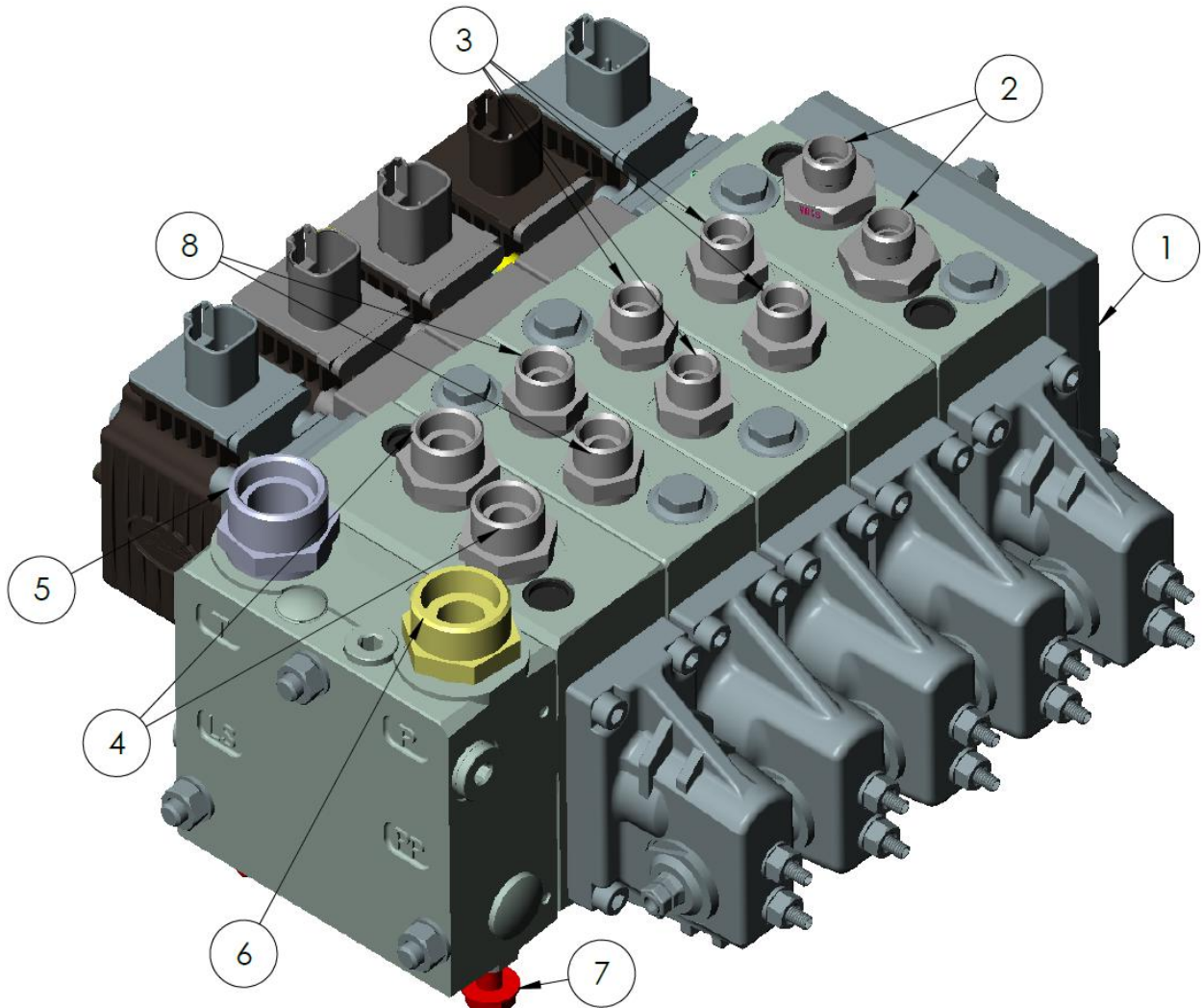

ITEM NO.	PART NUMBER	DESCRIPTION	QTY.
1	6703531	Valve PVG	1
2	9020307	Nipple	2
3	9040120	Nipple	4
4	9020116	Nipple	2
5	9020111	Nipple	1
6	9020308	Nipple	1
7	6702001	Bolt	4
8	9040117	Nipple	2

Scorpion 490-4 S&P 2 oilflows (ADGT1547)

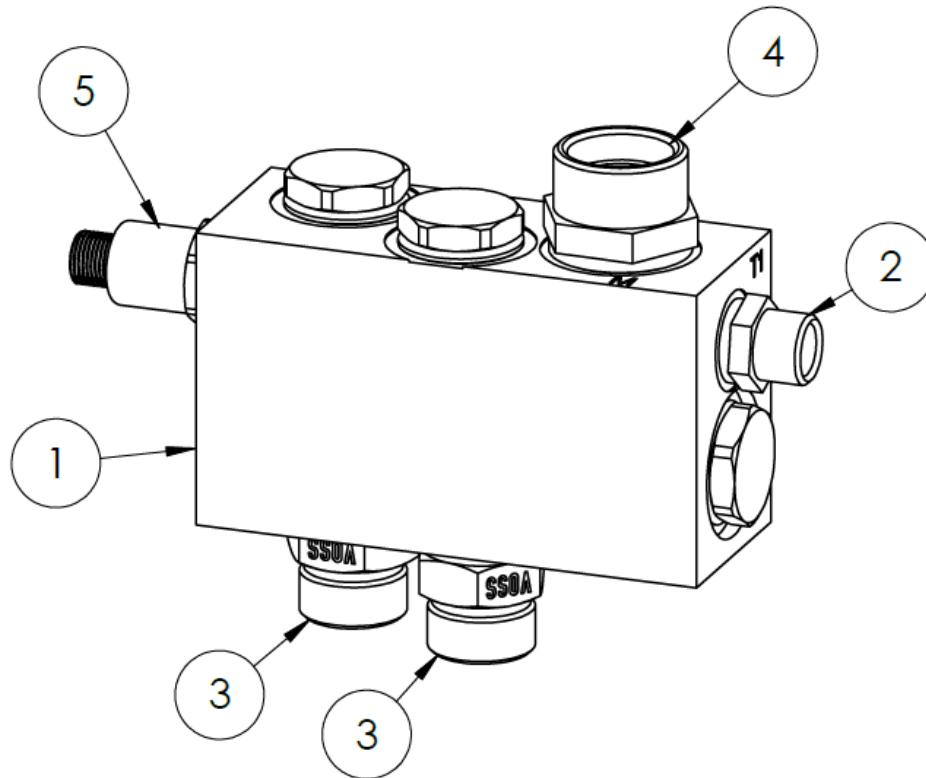

ITEM NO.	PART NUMBER	DESCRIPTION	QTY.
1	6701946	Valve	1
2	9040118	Nippel	1
3	6701998	Nipple	2
4	6702240	Nippel	1
5	9040135	Pressure transducer	1
NS	6701949	Nipple	1

Scorpion 490-4 P dobbelt contra valve auto flex (ADGT1308)

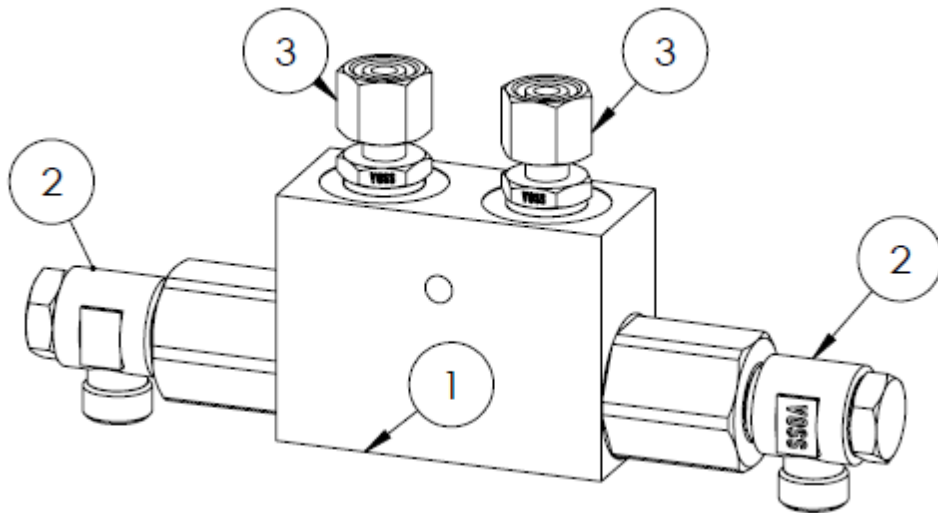

ITEM NO.	PART NUMBER	DESCRIPTION	QTY.
1	9040163	Valve	1
2	6701943	Nipple	2
3	9040136	Nipple	2

Scorpion 490-4 S&P main hydraulic drive rearmount (ADGT1501)

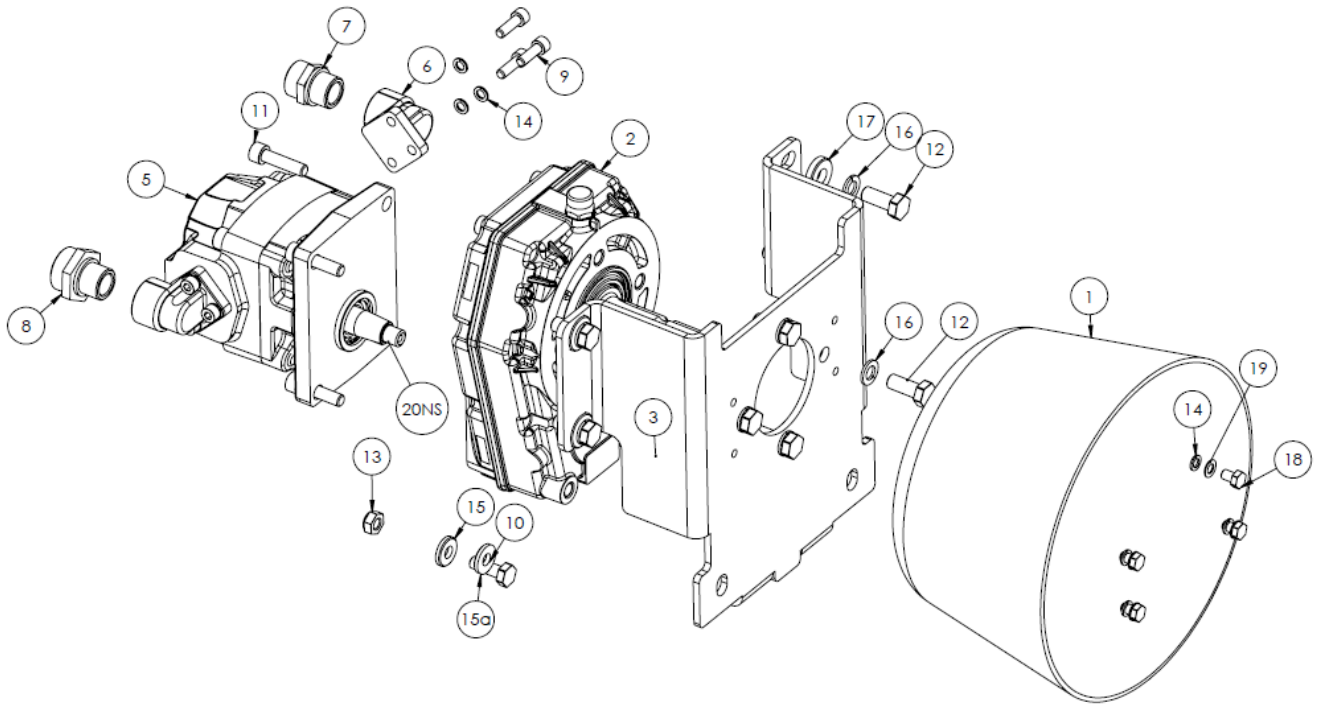

ITEM NO.	PART NUMBER	DESCRIPTION	QTY.
1	9020038	P.T.O shield	1
2	9020319.1	Gearbox	1
3	9020072	Bracket f/gearbox	1
5	6703268R	Hydraulic pump	1
6	200132.0	Portflange	2
7	9020111	Nipple	1
8	9020110	Nipple	1
9		Bolt (incl in pos. 6)	6
10	8222010	Bolt	4
11	9040241	Bolt	4
12	8222006	Bolt	12
13	8222023	Locknut	4
14	8222038	Washer (incl. in pos. 6)	10
15	8142003	HD Washer	8
15a	6701641	Washer	8
16	8222005	Washer	8
17	8222011	HD Washer	4
18	9040204	Bolt	4
19	2770433	Washer	4
NS20	9020318	Splinebushing	1
NS21	6703495	Portflange	

Scorpion 490-4 S&P main hydraulic drive frontmount (ADGT1501.1) NY

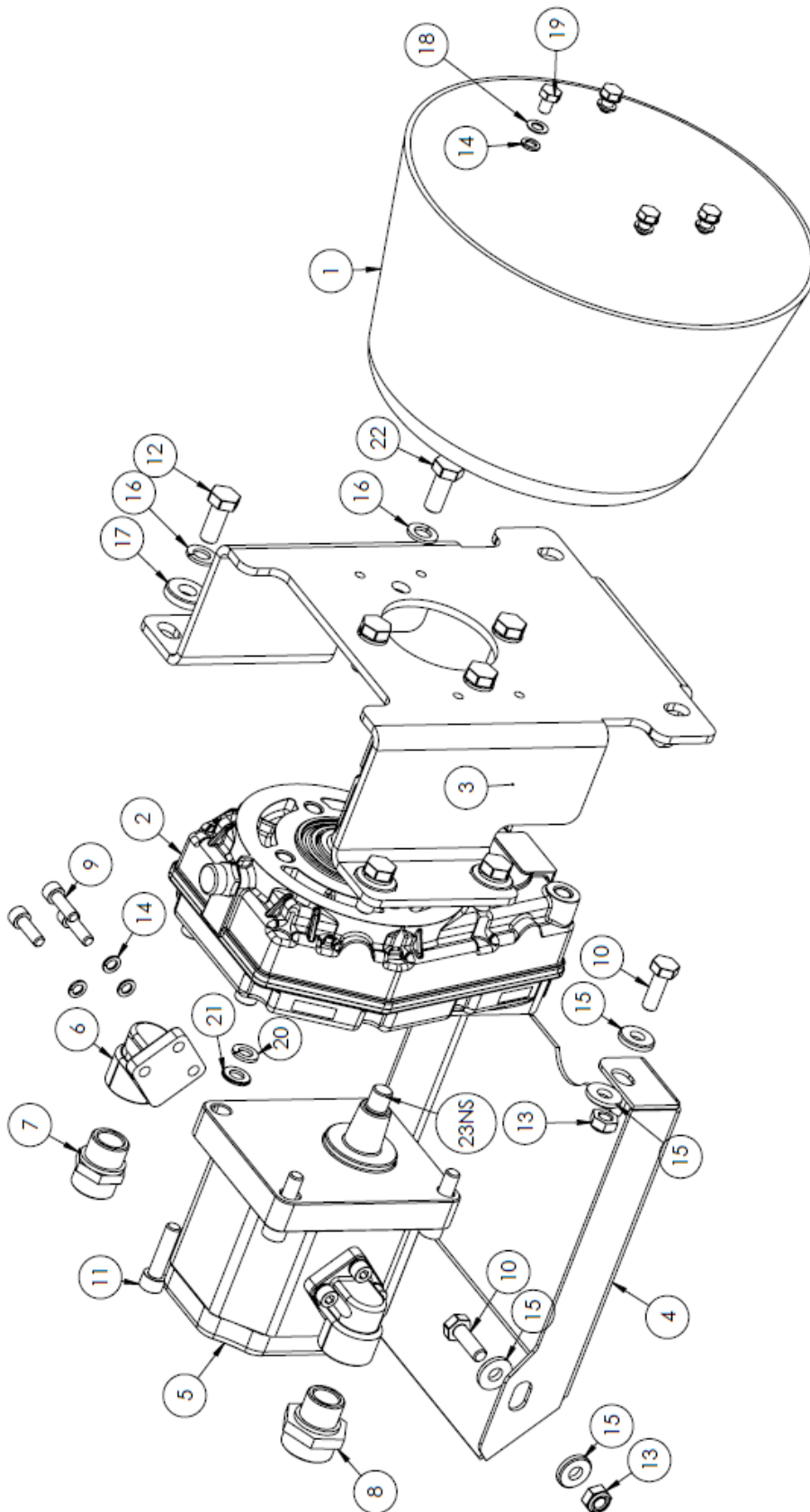

ITEM NO.	PART NUMBER	DESCRIPTION	QTY.
1	9020038	P.T.O shield	1
2	9020320	Gearbox	1
3	9020072	Bracket f/gearbox	1
4	9020073	Bottomplate	1
5	9040242	Hydraulic pump	1
6	200132.0	Portflange	2
7	9020110	Nipple	1
8	9020111	Nipple	1
9		Bolt (incl in pos. 6)	6
10	8222006	Bolt	4
11	9040241	Bolt	4
12	8222006	Bolt	4
13	8222023	Locknut	4
14	8222038	Washer (incl. in pos. 6)	10
15	8222011	Washer	8
16	8222005	Washer	8
17	8222011	Washer	4
18	8362011	Washer	4
19	9040204	Bolt	4
20	8222003	Springwasher	4
21	8222024	Washer	4
22	6701570	Bolt	4
NS23	9020318	Splinebushing	1
NS24	6703495	Portflange	1

Scorpion 490-4 S&P valve HIC (ADGT1052) **måske ny**

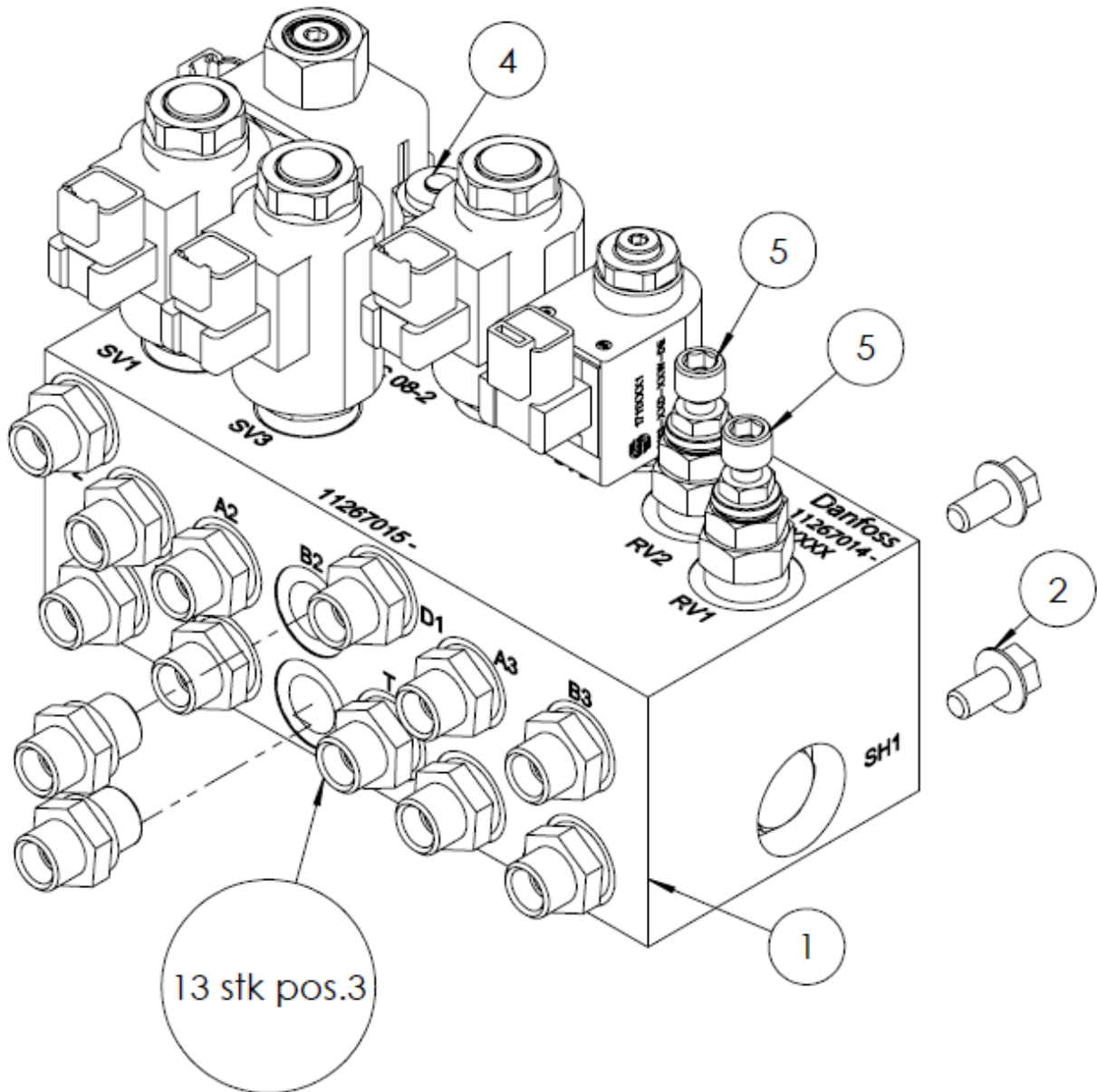

ITEM NO.	PART NUMBER	DESCRIPTION	QTY.
1	9040267	Valve	1
2	8142011	Bolt	4
3	9040120	Nipple	13
4	6701941	Check valve	1
5	6702267	Check valve	2

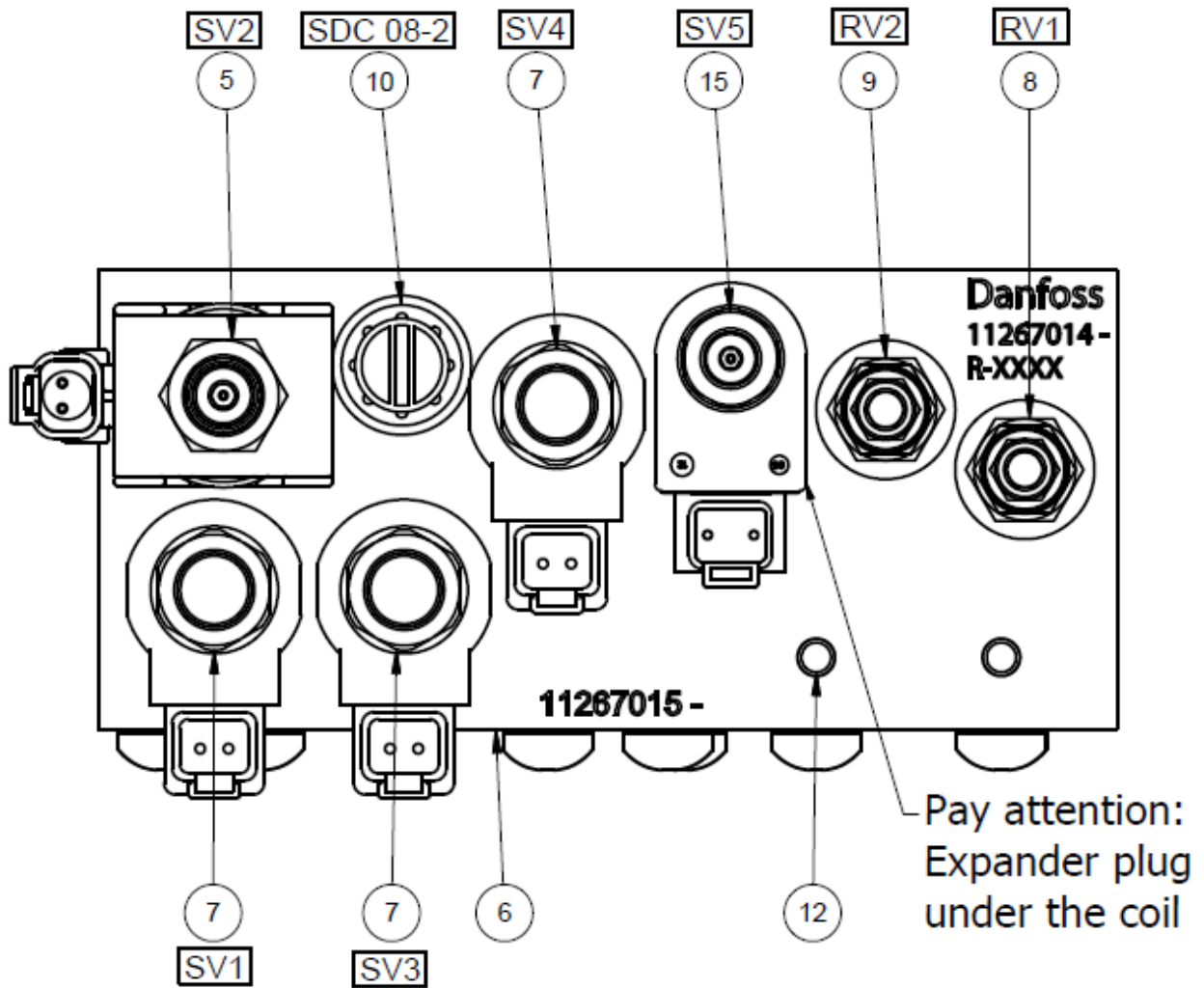

ITEM NO.	PART NUMBER	DESCRIPTION	QTY.
	9040267	Valve	1
5	6703384	Cartridge	1
5	6703383	Spole	1
7	6703287	Cartridge	3
7	6702719	Spole	3
8	6702267	Check valve	1
9	6702267	Check valve	1
10	6701941	Check valve	1
15	6703289	Cartridge	1
15	6703288	Spole	1

Scorpion 490-4 P joystick and controlbox



ITEM NO.	PART NUMBER	DESCRIPTION	QTY.
1	9040168/6702987	Joystick Right/Left	1
2	9040250	Control box	1
3	6702323	Ram mounts	1
4	9040156	Mounting kit SC 6&8	1
5	6702094	Manometerkit	1
6	6701855	Cable	1
7	6702550	Plug	1
8	9040177.3	Dustcover 2pcs.	

Scorpion 490-4 S&P PTO

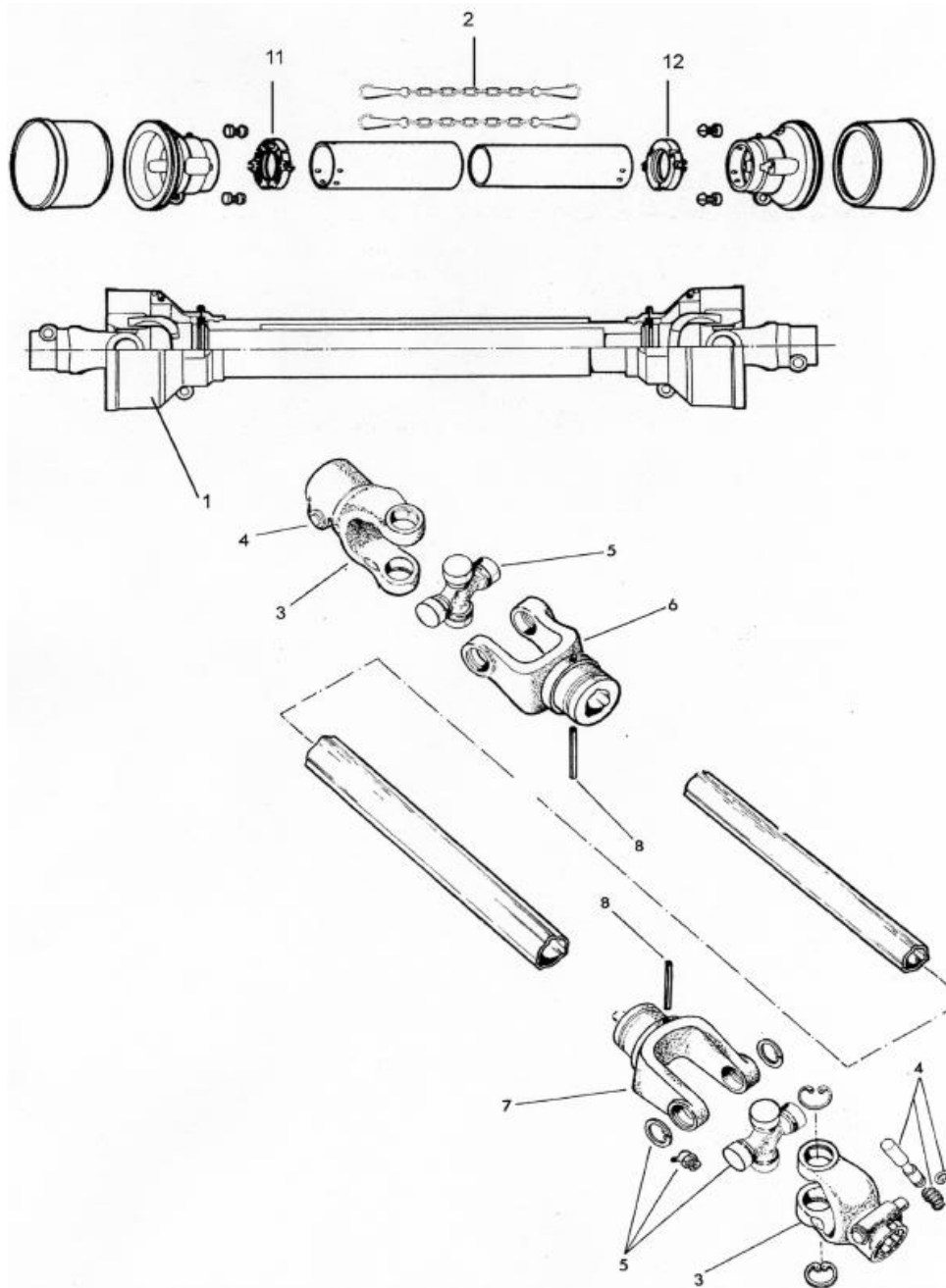

ITEM NO.	PART NUMBER	DESCRIPTION	QTY.
	6702669	PTO cpl.	1
1	6702670	Guard	1
2	6702665	Chain	2
3	6702671	Yoke 1-3/8 Z6	1
3a	6702672	Yoke 1-3/8 Z21	1
5	6702673	Cross	1

Scorpion 490-4 P switchboard and loom

Under konstruktion

Scorpion 490-4 S&P hydraulic hoses

When ordering individual hydraulic hoses, please see the location on the hydraulic diagram in the instruction manual.

For further questions contact Greentec

Scorpion 490-4 S&P 4 pkt. stabilization upper – Option

OPTE1133 / 1133.1 / 1133.2 / 1133.3 / 1133.4

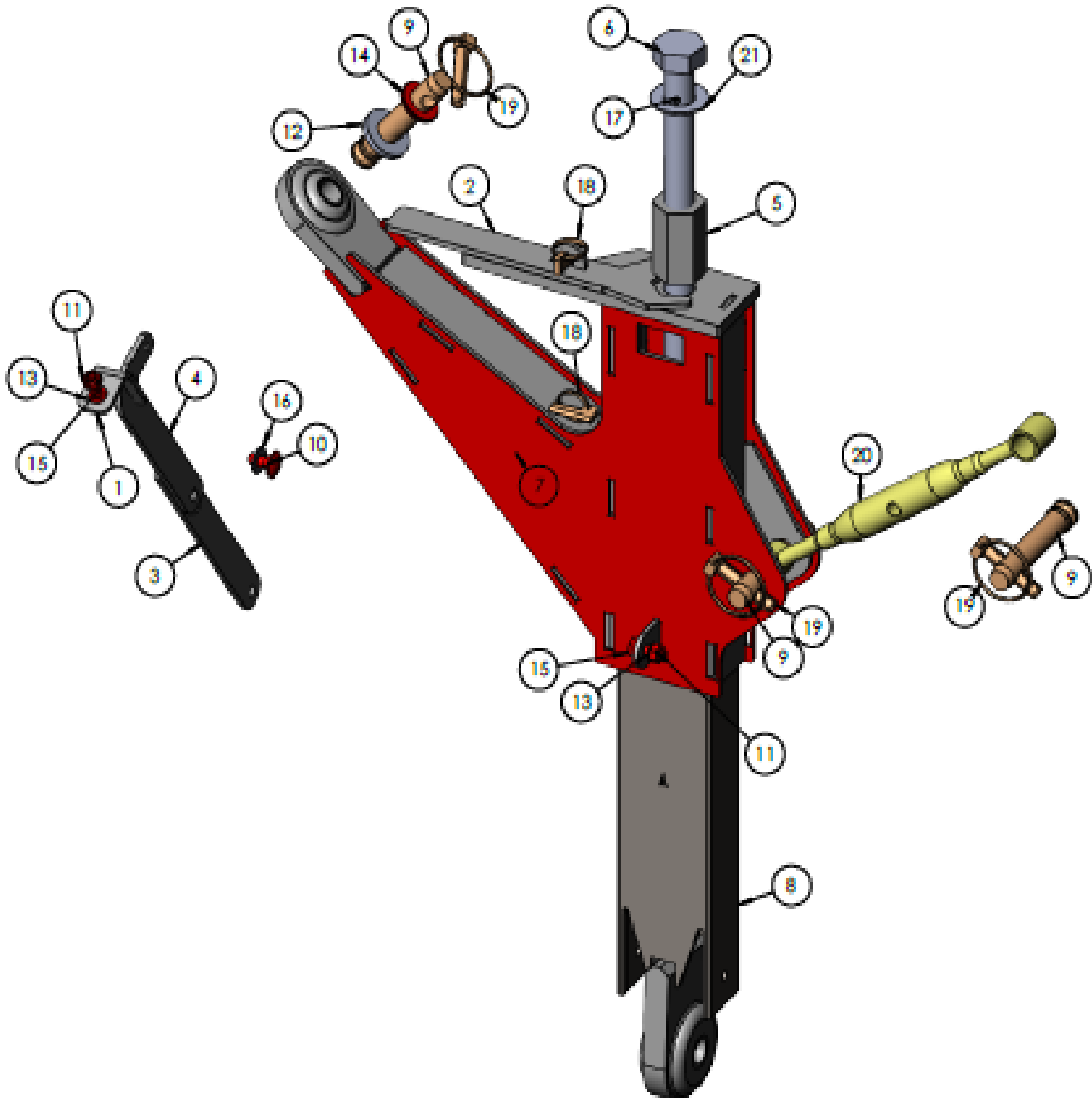

ITEM NO.	PART NUMBER	DESCRIPTION	QTY.
1	6701805.10	Holder f/tractor	1
2	6701805.11	Lock key	1
3	6701805.8	Inner holder	1
4	6701805.9	Outer holder	1
5	6701827	Crown nut	1
6	6701825	Bolt readjust	1
7	6701809	4.pkt stabilization short	1
7a	6701805	4.pkt stabilization long	1
7b	6701581	4.pkt stabilization ultra short	1
8	6701821	Kat. 1&2 short	1
8a	6701820	Kat. 1&2 long	1
8b	6701571	Kat. 1&2 ultra short	1
9	6310202	Toplink bolt	3
10	6701711	Bolt	1
11	6701629	Lock nut	2
12	6701830	Washer	1
13	8222037	Washer	2
14	6702047	Washer	1
15	6702001	Flangebolt	2
16	8362011	Washer	1
17	6701831	Pin	1
18	6706005	Split	2
19	9040213	Split	3
20	6701823	Toplink	1
21	6701828	Special washer	2
NS	6701829	Handle	1

OPTE1133.4 Ultra ultra short

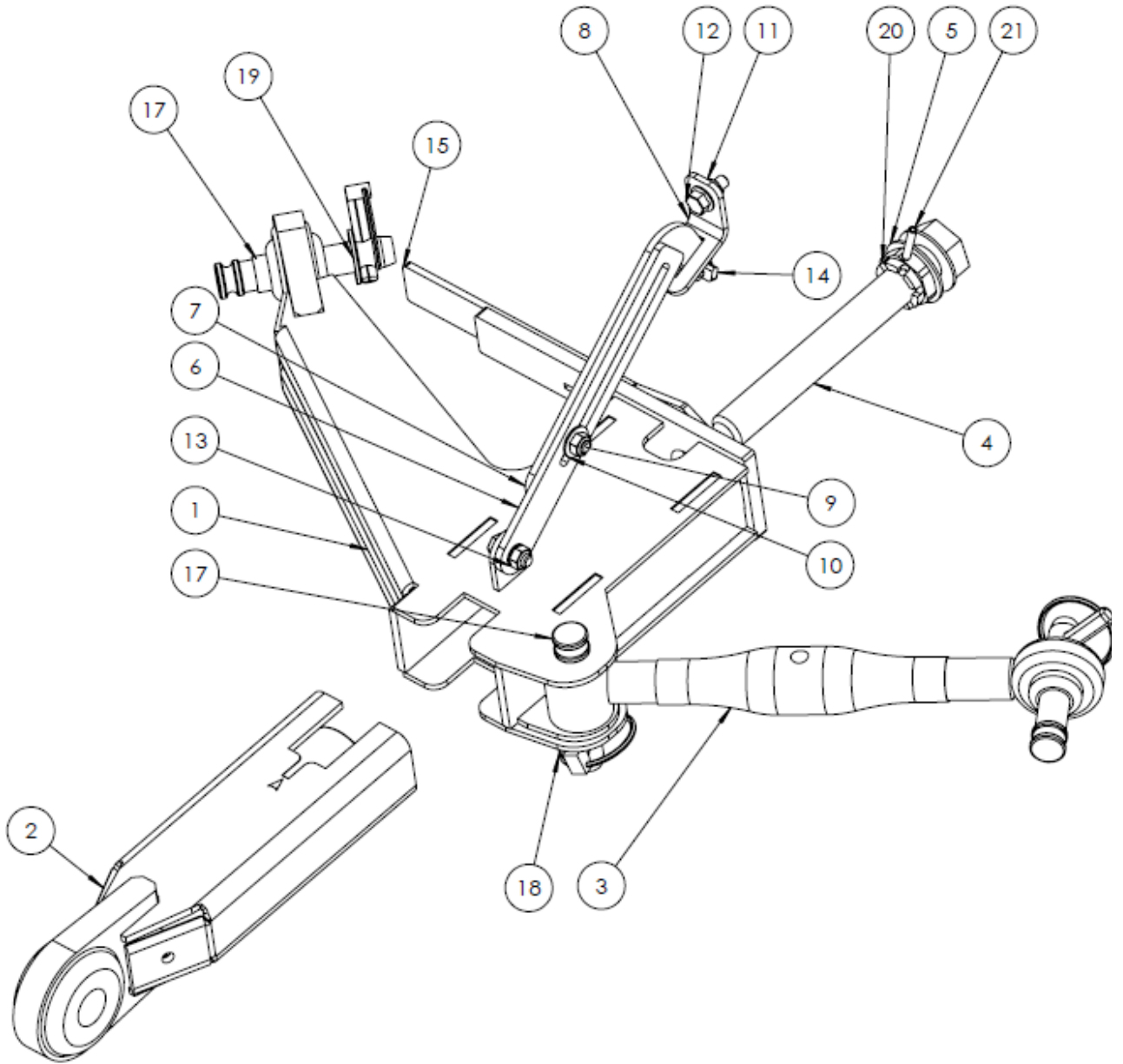

ITEM NO.	PART NUMBER	DESCRIPTION	QTY.
1	6703114	4.pkt stabilization ultra short	1
2	6703120	Kat. 1&2 ultra short	1
3	6701823	Toplink	1
4	6703122	Bolt readjust	1
5	6701828	Special washer	2
6	6701805.8	Inner holder	1
7	6701805.9	Outer holder	1
8	6701805.10	Holder f/tractor	1
9	6701711	Bolt	1
10	8362011	Washer	1
11	6701629	Lock nut	3
12	6702001	Flangebolt	2
13	8222037	Washer	2
14	6706005	Ringsplit	2
15	6701805.11	Lock key	1
16	6701805.15	Bushing	1
17	6310202	Toplink bolt	3
18	9040213	Split	3
19	6702047	Washer	1
20	6701827	Crown nut	1
21	6701831	Pin	1
NS	6701829	Handle	1

Scorpion 490-4 P arm cpl.

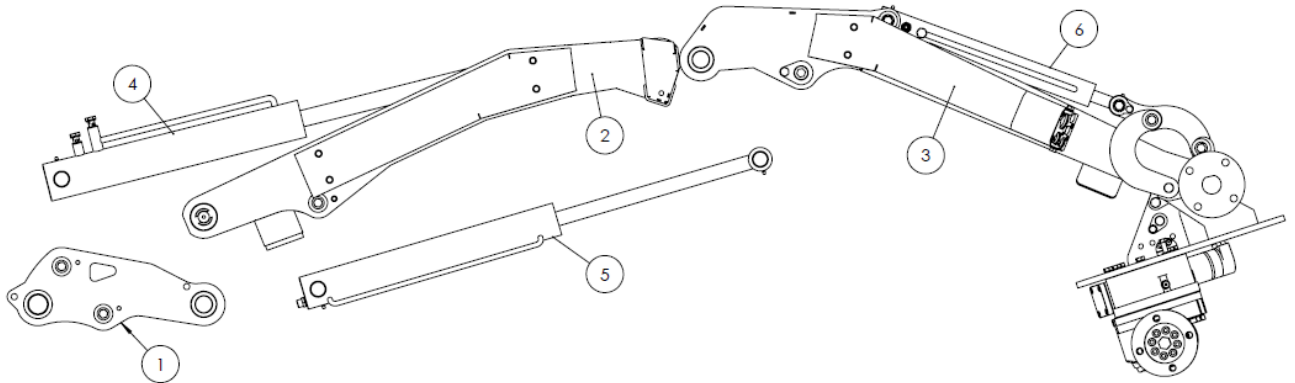

ITEM NO.	PART NUMBER	DESCRIPTION	QTY.
1		Lift arm "see assambly drawing"	1
2		Complete innerarm "see assambly drawing"	1
3		Complete outerarm "see assambly drawing"	1
4	Cylinder 3	Cylinder "see assambly drawing"	1
5	Cylinder 4	Cylinder "see assambly drawing"	1
6	Cylinder 5	Cylinder "see assambly drawing"	1

Scorpion 490-4 P outer arm (ADGT1512R/L)

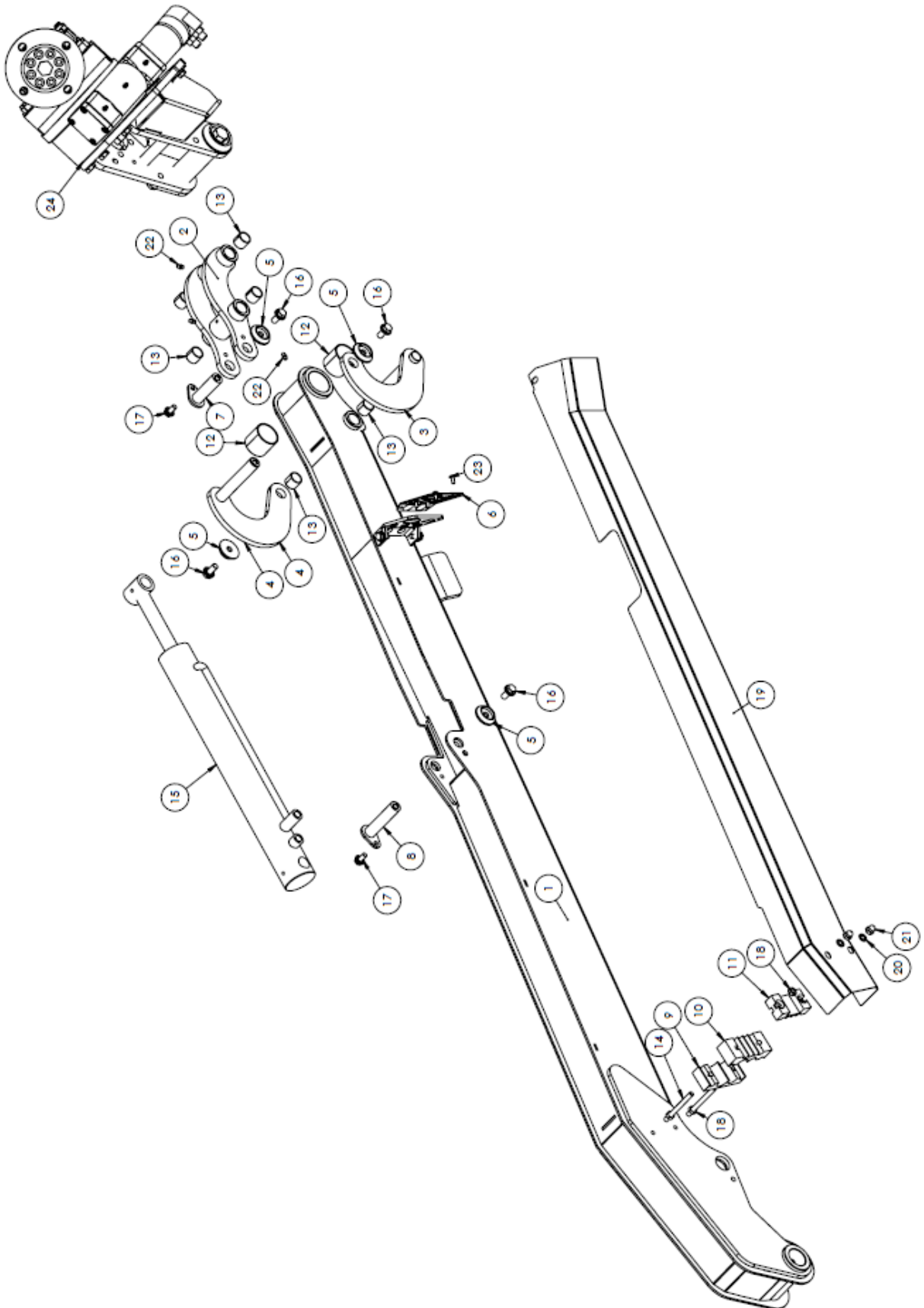

ITEM NO.	PART NUMBER	DESCRIPTION	QTY.
1	6703332R/6703332L	Outerarm R/L	1
2	9020003	Crowd bracket	1
3	9020005	Curved plate R	1
4	9020004	Curved plate L	1
5	9020011	Stopwasher	4
6	9020013	Stopplate	1
7	9020009	Pear pin	1
8	9020037	Pear pin	1
9	9020023	Hoseholder inner	1
10	9020024	Hoseholder mid	1
11	9020025	Hoseholder outer	1
12	9020028	Bronzebushing	2
13	9020030	Bronzebushing	6
14	9020032	Support bolt	2
15	Cylinder 5	Cylinder "see assambly drawing"	1
16	6702626	Flangebolt	4
17	6702594	Flangebolt	4
18	81822003	Nut	4
19	6703334R/6703334L	Cover for outer arm R/L	1
20	6703424	Washer	2
21	81822004	Nut	2
22	8222027	Greasenipple	4
23	6702166	Bolt	4
24		Rotor flex "see assambly drawing"	1

Scorpion 490-4 S&P inner arm (ADGT1511R/L)

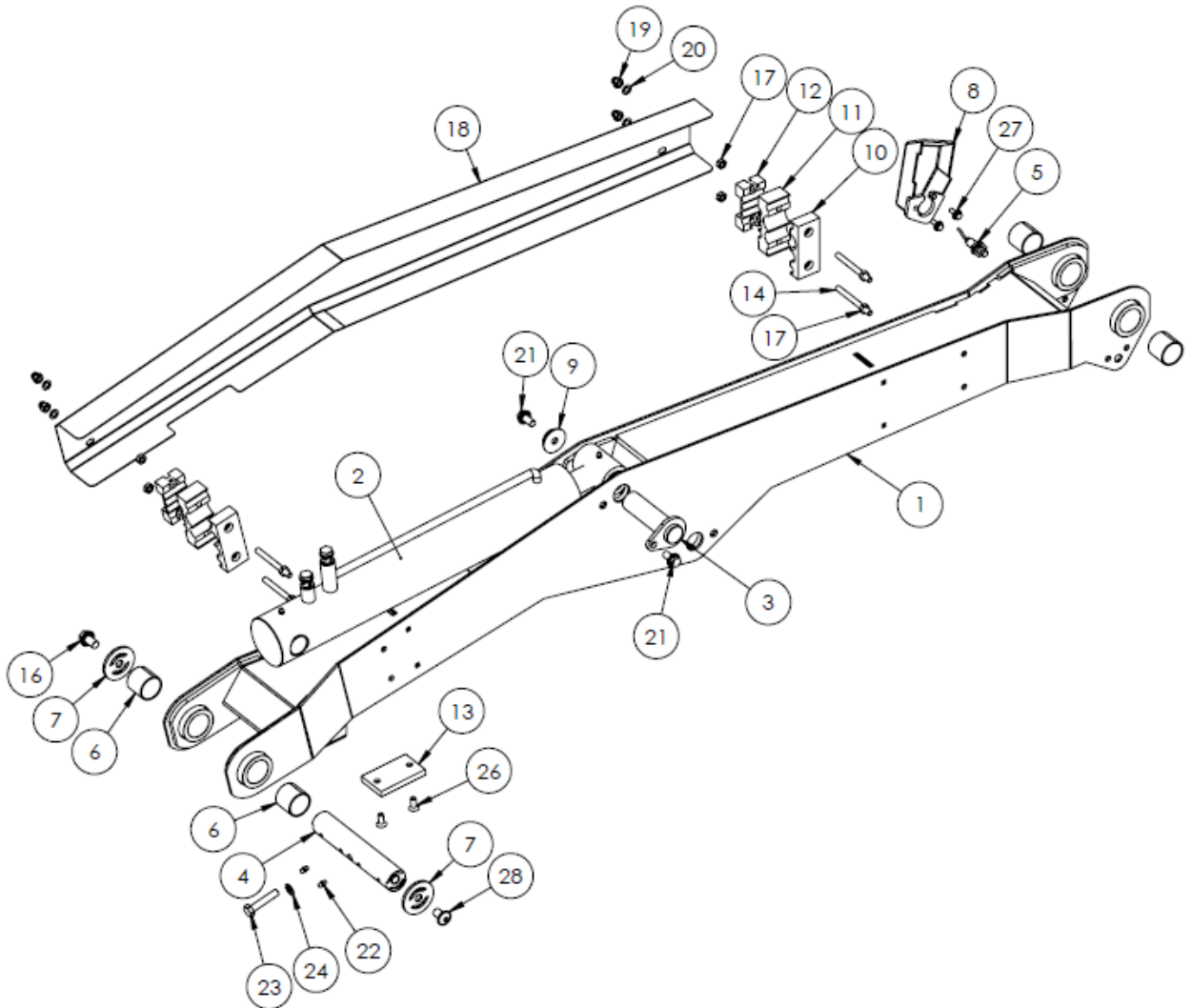

ITEM NO.	PART NUMBER	DESCRIPTION	QTY.
1	6703331	Innerarm	1
2	9020041	Cylinder nbr.3	
3	9020021	Pear pin	1
4	9020016	Special pin	1
5	9040110	Sensor	1
6	9020027	Bronzebushing	4
7	9020017	Lock washer	2
8	9020095	Proction for sensor	1
9	9020011	Stopwasher	1
10	9020023	Hoseholder inner	2
11	9020024	Hoseholder mid	2
12	9020025	Hoseholder outer	2
13	9020096	Spacer	1
14	9020032	Supportbolt	4
15	8222005	Washer	1
16	6702617	Flangebolt	1
17	81822003	Nut	6
18	6703333R/L	Cover for innerarm	1
19	81822004	Top nut	4
20	6703424	Washer	4
21	6702626	Flangebolt	2
22	8222027	Greasenipple	2
23	6701994	Bolt	1
24	8222003	Washer	1
26	9040180	Bolt	2
27	8222020	Flaangebolt	2
28	6702011	Bolt	1

Scorpion 490-4 S&P lift arm (ADGT1033R/1033L) måske ny

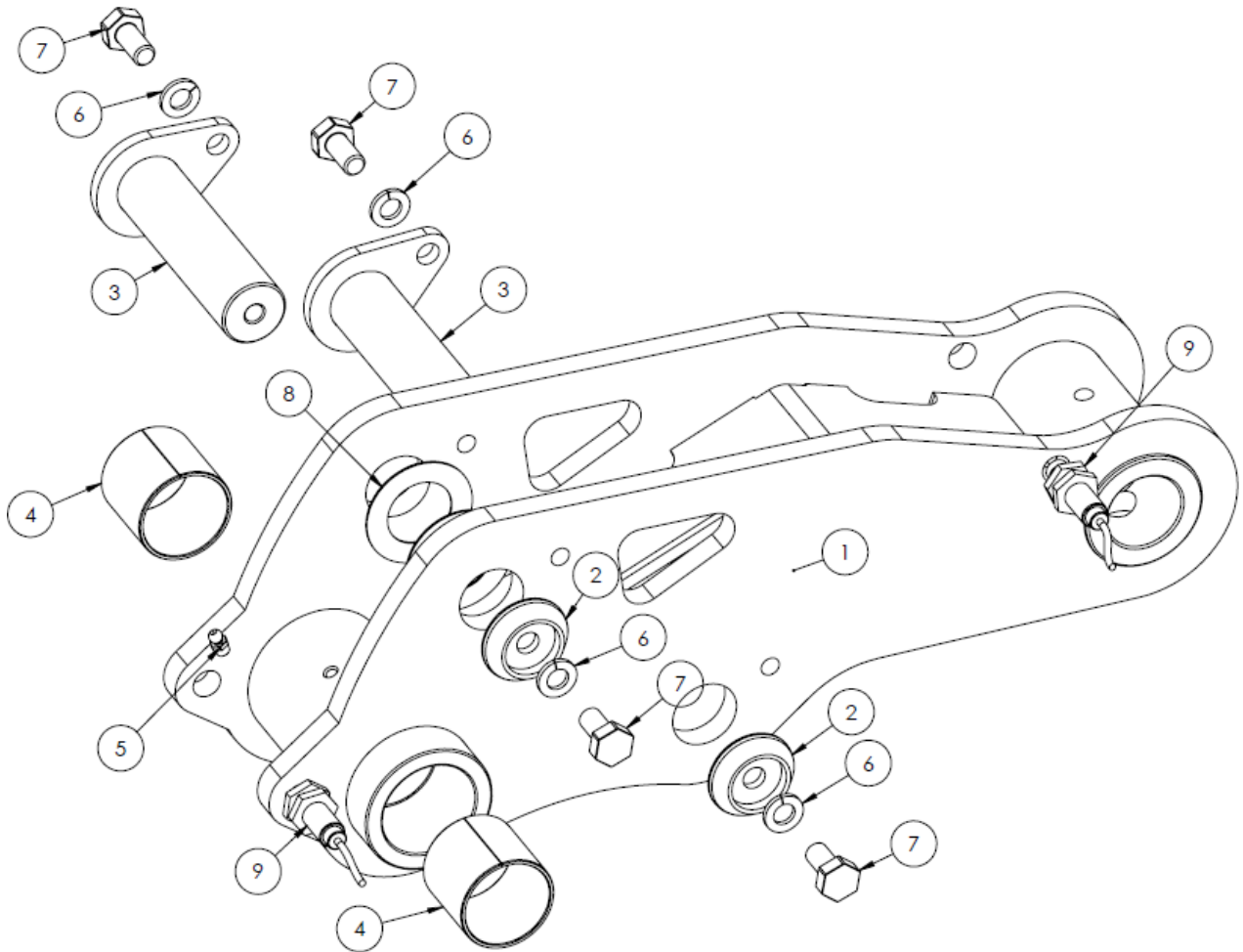

ITEM NO.	PART NUMBER	DESCRIPTION	QTY.
1	9020002	Liftarm	1
2	9020011	Stopwasher	2
3	9020026	Pear pin	2
4	9020028	Bronzebushing	2
5	8222027	Greaseneripple	1
6	8222003	Washer	4
7	8222002	Bolt	4
8	9020120	Distance washer	2
9	9040110	Sensor	2

Scorpion 490-4 P rotor flex (ADGT1257/1257.1)

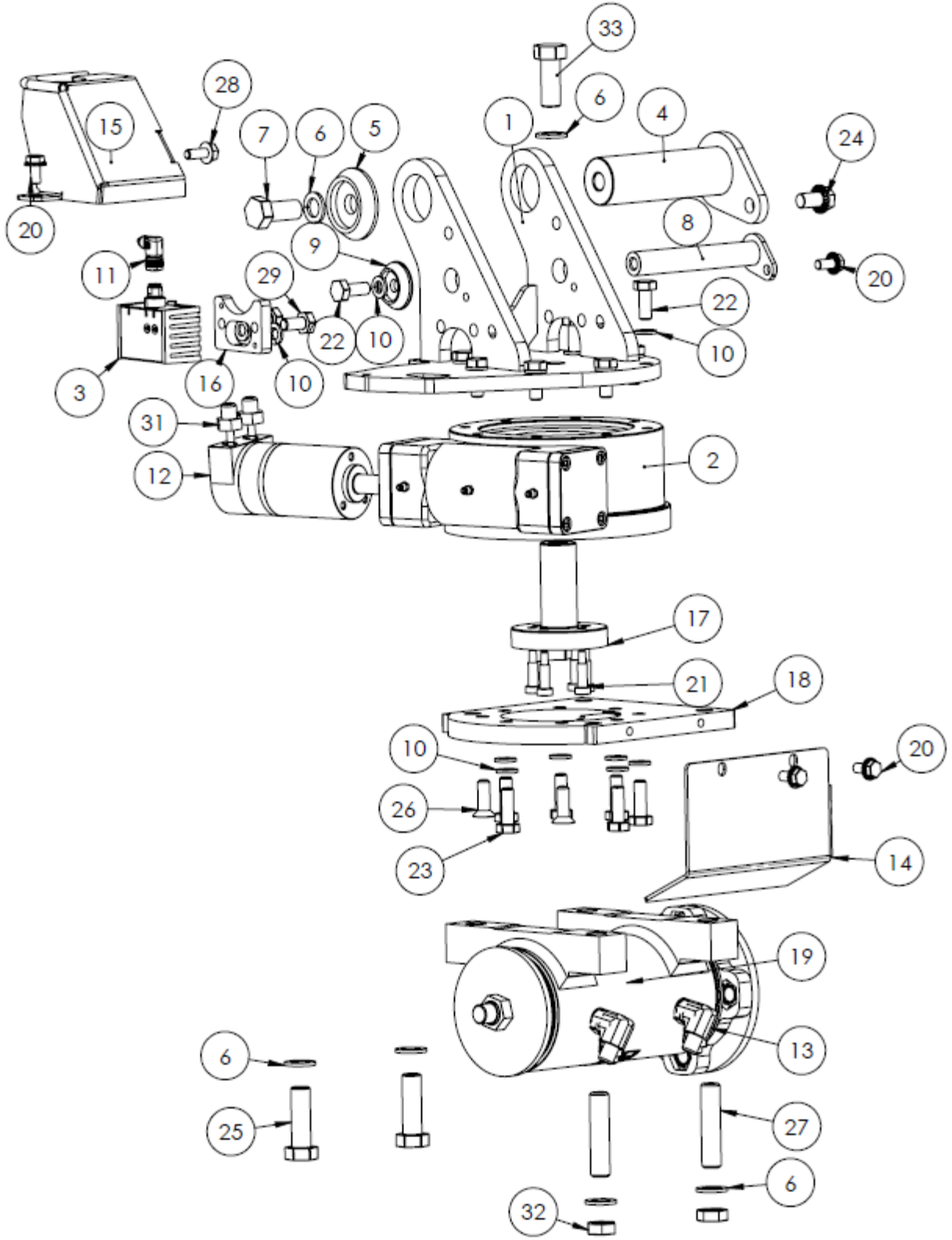

ITEM NO.	PART NUMBER	DESCRIPTION	QTY.
1	6701860R/L	Rotorflex top R	1
2	6701861	Rotorflex	1
2+12	6702282	Rotorflex kpl. incl motor Right	1
2+12	6702282.1	Rotorflex kpl. incl motor Left	1
3	6701742	Autoflexstying	1
4	6701865	Pin	1
5	9020010	Stopwasher	1
6	8222013	Washer	6
7	8752004	Bolt	1
8	6701866	Pin	1
9	9020011	Stopwasher	1
10	8222003	Washer	17
11	6701741	Cable	1
12	6701992	Motor	1
14	6701870R/L	Cover f/rotor	1
15	6701869R/L	Cover R f/rotorflex	1
16	6701915	Mountplate f	1
17	6701913	Rotorflex stop	1
18	6701868R/L	Middelplate f/feeler	1
19		Rotor	1
20	6702594	Bolt	1
21	6702252	Bolt	6
22	8222001	Bolt	9
23	8222010	Bolt	6
24	6702617	Bolt	1
25	2770425	Bolt	2
26	6701871	Bolt	2
27	6701921	Pinolbolt	2
28	6702594	Bolt	2
29	8222002	Bolt	2
31	6702048	Nipple	2
32	2770449	Nut	2
33	9040185	Bolt	1

Scorpion 490-4 P rotor (ADGT1258)

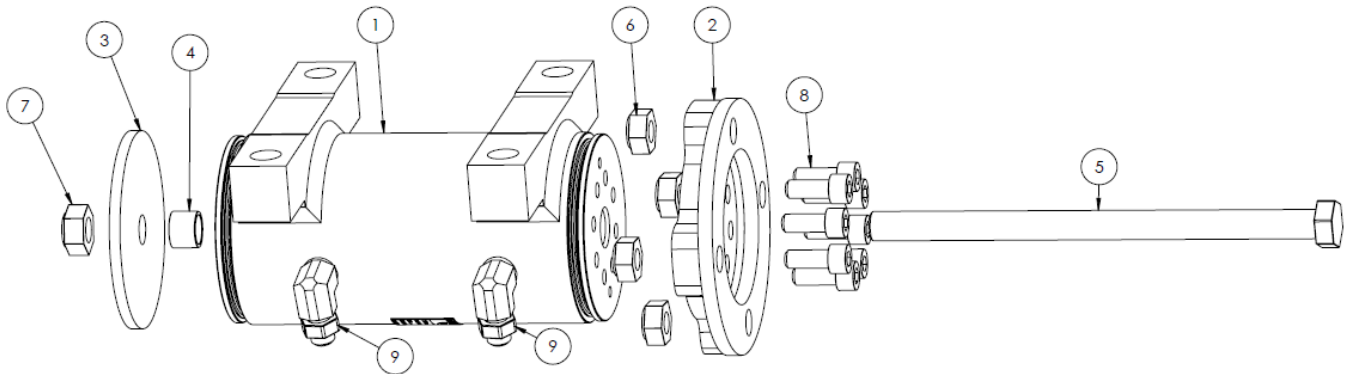

ITEM NO.	PART NUMBER	DESCRIPTION	QTY.
1	6701862	Motor	1
2	6701863	Mountplate	1
3	6701873	Backplate	1
4	6701916	Centerring	1
5	6701874	Bolt	1
6	1061042	Nut	4
7	81822001	Nut	1
8	8222001	Bolt	8
9	6701918	Nipple	2

Scorpion 490-4 S&P slewcylinder (cylinder 1) NY skal der ikke nipler i ??

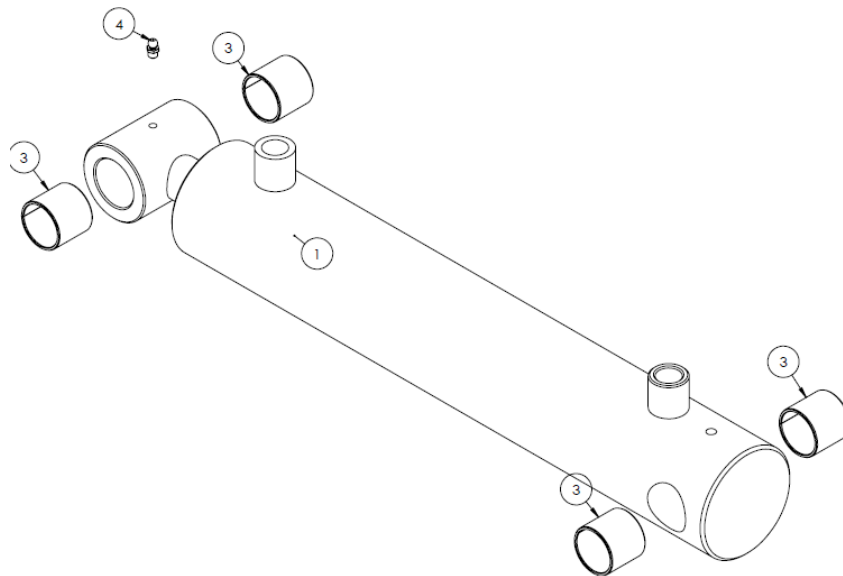

Cylinder model 2



Holes

ITEM NO.	PART NUMBER	DESCRIPTION	QTY.
1	6703342	Cylinder	1
3	9020029	Bronzebushing	2
4	8222027	Greasenipple	3
5	6703012	Banjo	2
6	6703003	Seals	4
NS	6703236	Sealkit f/ cylinder model 2 (holes), after 2021	1

Scorpion 490-4 S&P liftcylinder (cylinder 2)

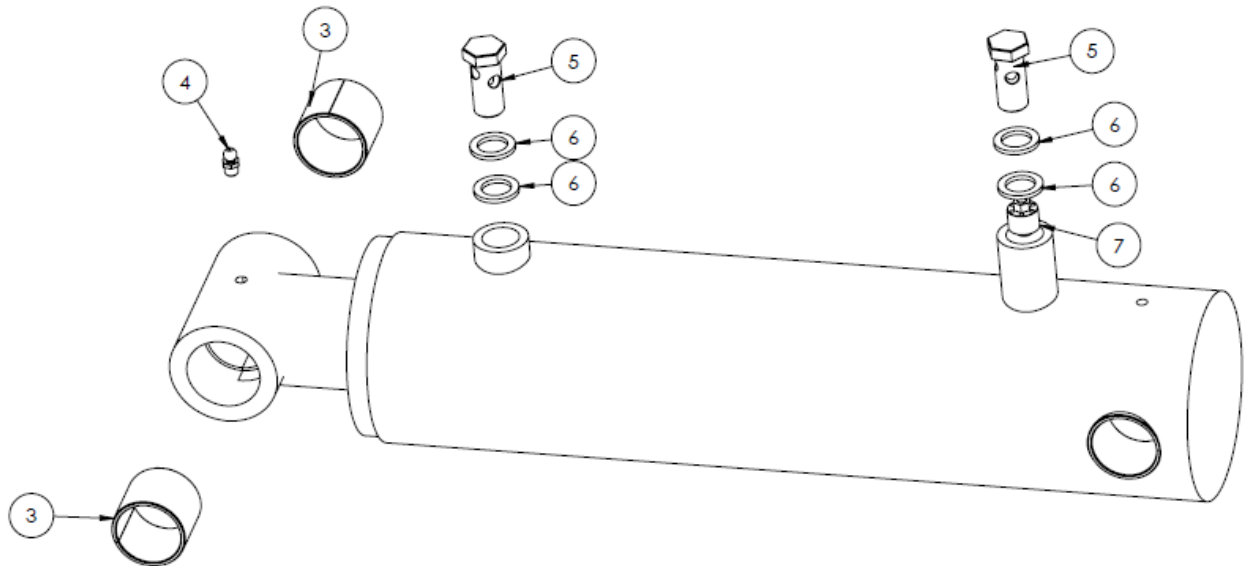

ITEM NO.	PART NUMBER	DESCRIPTION	QTY.
1	6703301	Cylinder	1
3	9020029	Bronzebushing	4
4	6703888	Greasenipple	1
5	6703012	Banjo	2
6	6703030	Seals	4
8	9040129	Hose burst cart	1
NS	6703841	Sealkit f/ cylinder	1

Scorpion 490-4 S&P cylinder (cylinder 3)

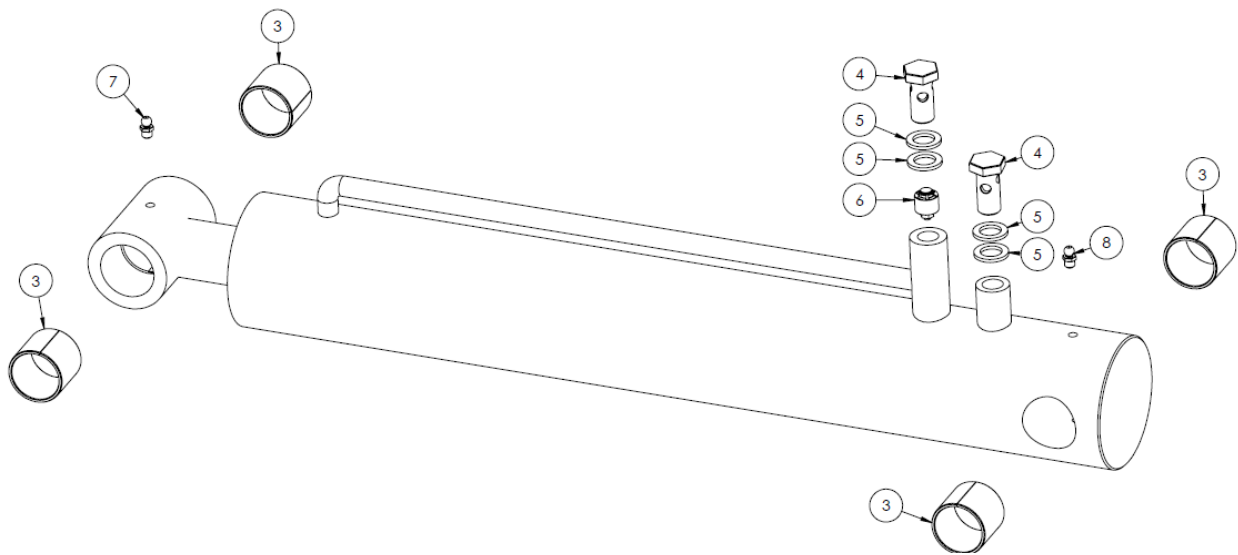

ITEM NO.	PART NUMBER	DESCRIPTION	QTY.
1	9020041	Cylinder	1
3	9020029	Bronzebushing	4
4	8143003	Banjo bolt	2
5	8143005	Seals	4
6	9040262	Hose burst card	1
7	8222027	Greasnipple	1
8	2770497	Greasnipple 90°	1
NS	6703864	Sealkit f/ cylinder	1

Scorpion 490-4 S&P dippern cylinder (cylinder 4)

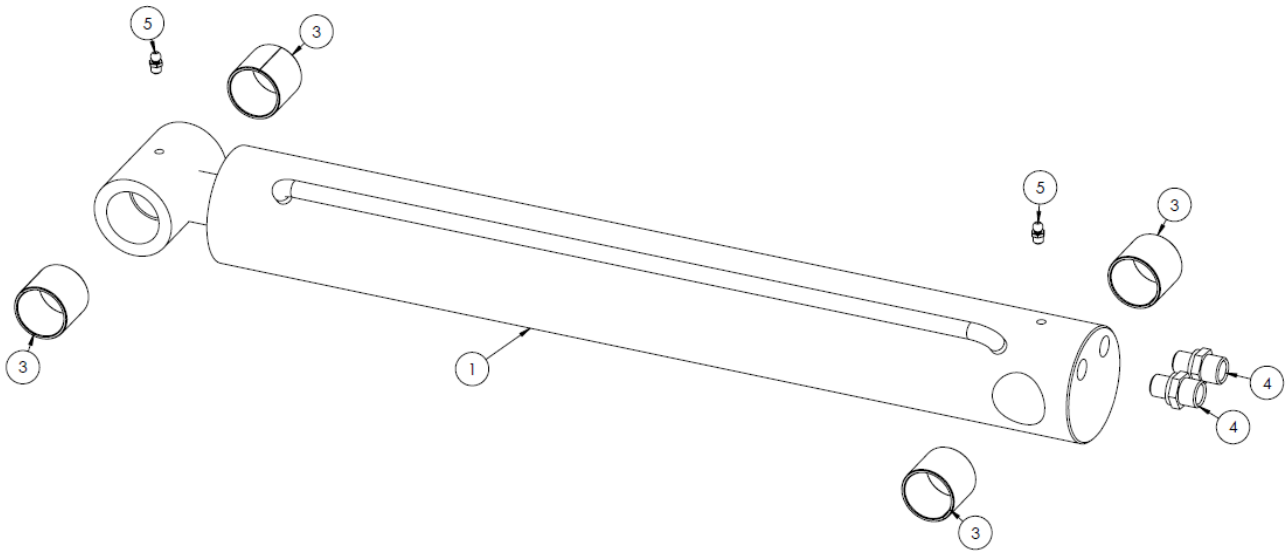

ITEM NO.	PART NUMBER	DESCRIPTION	QTY.
1	9020052	Cylinder	1
3	9020029	Bronzebushing	4
4	9040118	Nipple	2
5	8222027	Greasenipple	2
NS	6703865	Sealkit f/ cylinder	1

Scorpion 490-4 P headcylinder (cylinder 5)

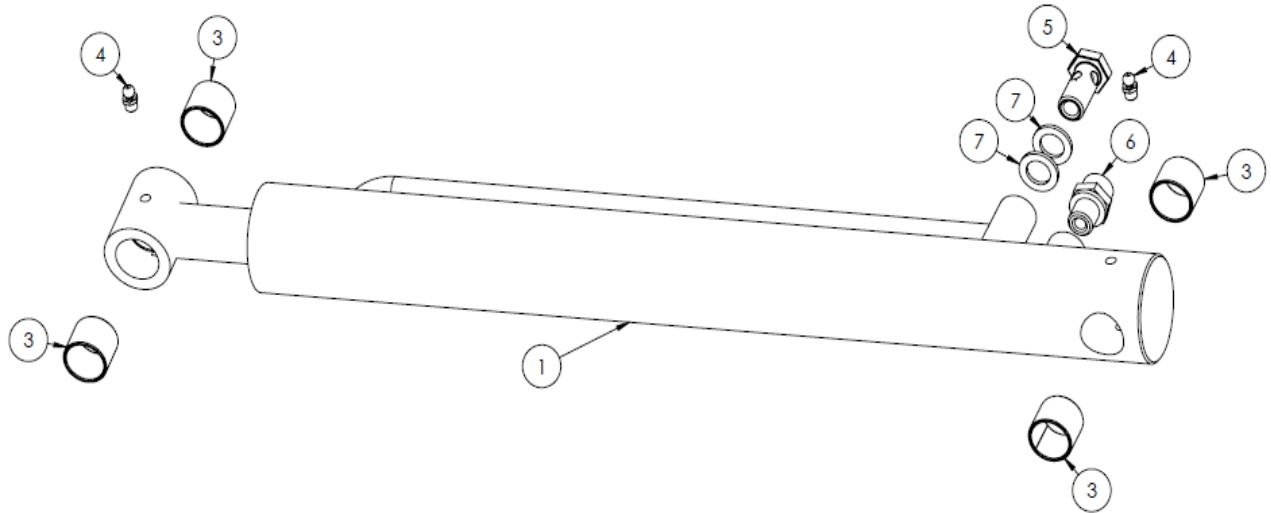

ITEM NO.	PART NUMBER	DESCRIPTION	QTY.
1	9020045.1	Cylinder	1
3	9020030	Bronzebushing	4
4	8222027	Greasenipple	2
5	8143003	Banjo bolt	1
6	9040118	Nipple	1
7	8143005	Seals	2
NS	6703863	Sealkit f/ cylinder	1

Stickers

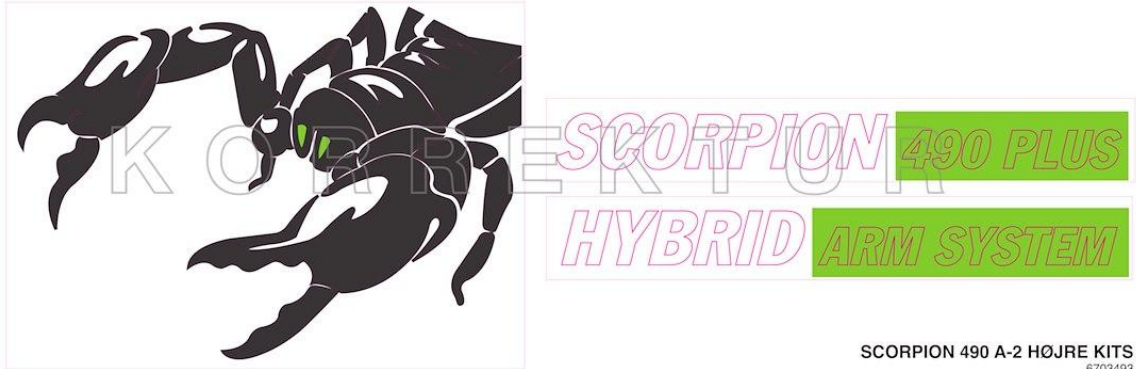

SCORPION 490 A-2 HØJRE KITS
6703493



SCORPION 490 A-1 HØJRE KITS
6703493

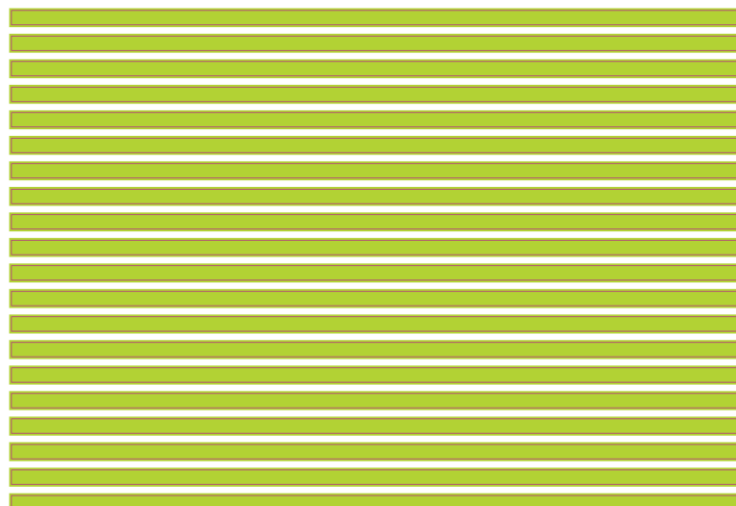

SCORPION 330/430 Striber for arm – 1000 x 20 mm

SCORPION 330/430 C STRIBER KITS
6701749

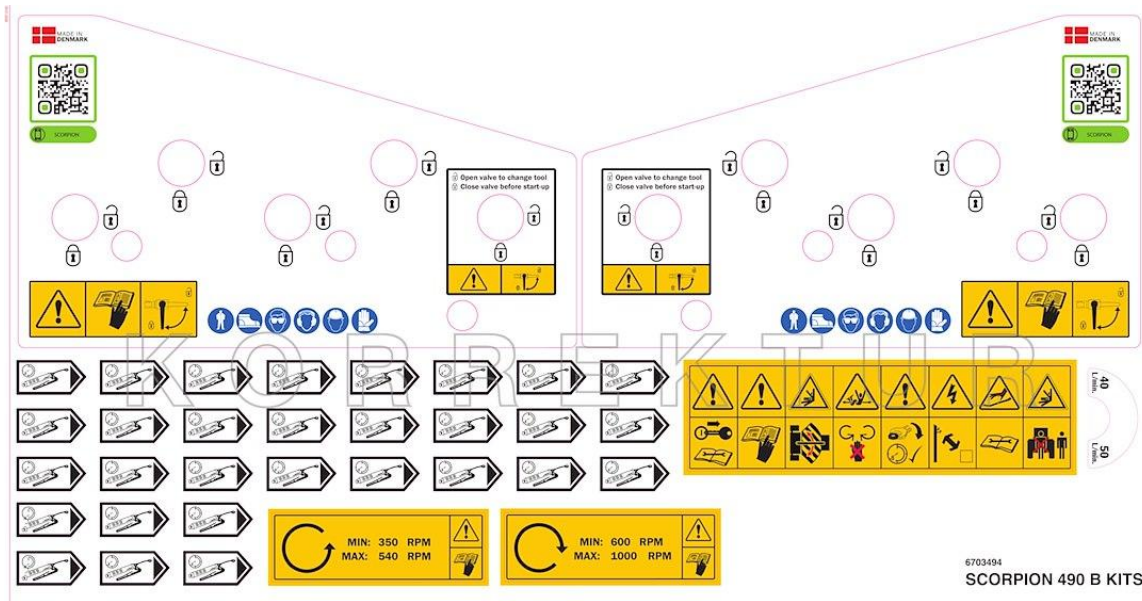

6703494
SCORPION 490 B KITS

ITEM NO.	PART NUMBER	DESCRIPTION	QTY.
1	6704396/6703493.1	Stickers A kits cpl Right/Left SC 490	1
2	6701749	Stickers C kits 330/430/490	1
3	6703494	Stickers B kits 490	1



Merkurvej 25 | DK-6000 Kolding | Tel.: +45 75 55 36 44 | info@GreenTec.eu | www.GreenTec.eu

Cutting Edge Technology